

Valve testing system VPS 504 for multiple actuators

8.10

DUNGS®

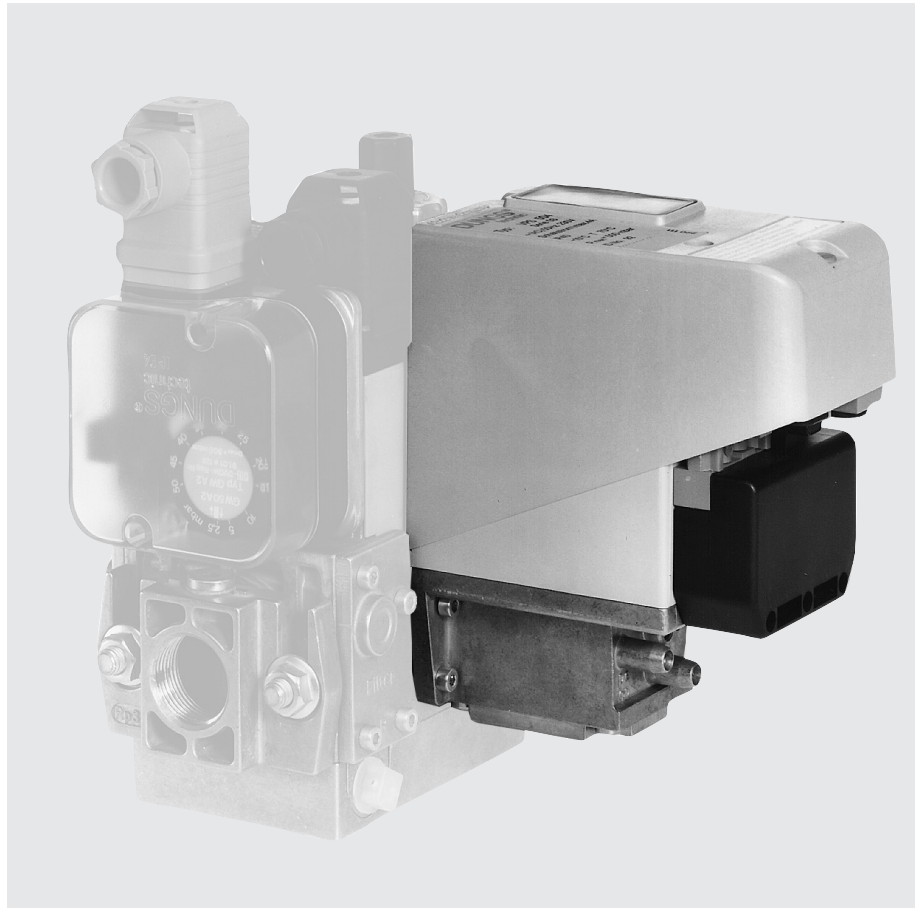

Technical description

The VPS 504 is the valve proving system for DUNGS multiple actuators. The valve proving system complies with EN 1643:

- Equipment operates independent of residual pressure in the range of the permissible operating range.
- Test volume ≤ 4 l
- Setting work not necessary on site
- Short test period: min. 10 s, max. 26 s
- Tightness or leaks are displayed by an LED
- External fault display possible for series 02, series 04 and series 05
- Group fault alarm optional for series 01 (SSM)
- Suitable for TRD systems
- Electrical connection possible by plug connection series 01, 02, 03. No rewiring is required for contact allocation as per DIN 4791.
- Series 04 and series 05: electrical connection at screw terminals via PG 13.5 cable entry

Application

Valve proving system for DUNGS single valves, DMV double solenoid valve and GasMultiBloc MB.

The VPS 504 can also be used for monitoring the DUNGS solenoid valves up to DN 80, with and without bypass connection.

24 VDC design for gas motors.

Suitable for gases of gas families 1, 2, 3 and other neutral gaseous media.

Approvals

EC type test approval as per EC Gas Appliance Directive:

VPS 504... CE-0085 AP 0168

EC type test approval as per EC Pressure Equipment Directive:

VPS 504... CE0036

Approvals in other important gas consuming countries. Special design for the North American market with U_L, FM and CSA registration.

Specifications

Operating pressure	max. 500 mbar (50 kPa)		
Test volume	≤ 4.0 l		
Pressure increase by motor pump	≈ 20 mbar		
Nominal voltage (Permissible voltage range)	230 V AC (-15%) to -240 V (+6%), VPS 504 series 05: 24 VDC For further voltages, refer to type overview		
Frequency	VPS series 01-04:	50 Hz or 60 Hz	
	Series 05:	DC	
Rating requirement	During pumping time approx. 60 VA, in operation 17 VA		
Prefuse (provided by customer)	10 A quick-acting or 6.3 A slow-acting fuse		
Fuse installed in housing cover, replaceable	Microfuse 6.3 slow-blow L 250 V; IEC-127-2/III (DIN 41 662)		
Switching current	Operating output	VPS 504 Series 01, 02, 03, 04, 05:	max. 4 A
	Interference output	VPS 504 Series 02, 04, 05:	max. 1A
	Refer to motor startup current!		
Degree of protection	VPS 504 Series 01, 02, 03:	IP 40	
	VPS 504 Series 04, 05:	IP 54	
Ambient temperature	50 Hz 230 VAC -15°C to +70°C others: -15°C to +60°C		
Release time	Approx. 10 - 26 s, depending on test volume and input pressure		
Sensitivity limit	max. 50 l/h At inlet pressures of < 50 mbar, limit pressure rates well below 50 l of air per hour occur due to the mode of operation. This allows for applications involving low inlet pressures.		
Switch-on duration of control	100 % ED		
Max. number of test cycles	20/h. Wait for at least 2 minutes after carrying out more than 3 consecutive test cycles.		
Installation position	vertical, horizontal, not upside down		
Media			
• Standard model	Gas families 1, 2, 3 and other gaseous media. Not suitable for butane.		
• Liquefied gas model	Gas family 3 and butane		

VPS 504 sectional diagram

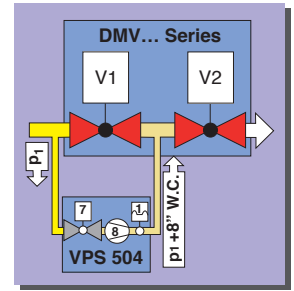
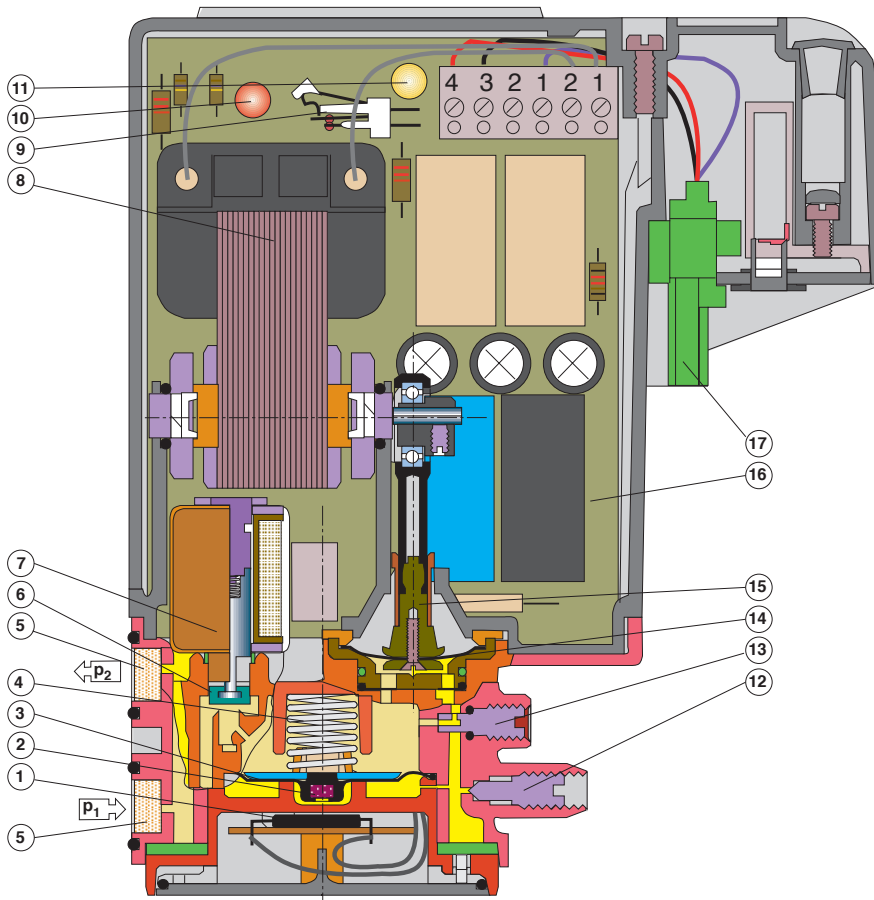

- | | | | | | |
|---|----------------------------|----|---------------------|----|-------------------|
| 1 | Hall switch | 7 | Solenoid valve coil | 13 | Volume restrictor |
| 2 | Solenoid | 8 | Pressure pump | 14 | Pump diaphragm |
| 3 | Pressure switch diaphragms | 9 | Unlock switch | 15 | Pump linkage |
| 4 | Compression spring | 10 | Fault lamp | 16 | PCB |
| 5 | Filter | 11 | Operating lamp | 17 | Plug connection |
| 6 | Solenoid valve anchor | 12 | Test nipple | 18 | Equipment fuse |
| | | | | 19 | Spare fuse |

Functional description

The VPS 504 operates depending on pressure build-up.

The program module starts to function when heat is requested.

Test is performed depending on the burner functional procedure:

Check **prior to** burner start or

Check **during** pre-purge period or

Check **after** burner shut-down

Function principle

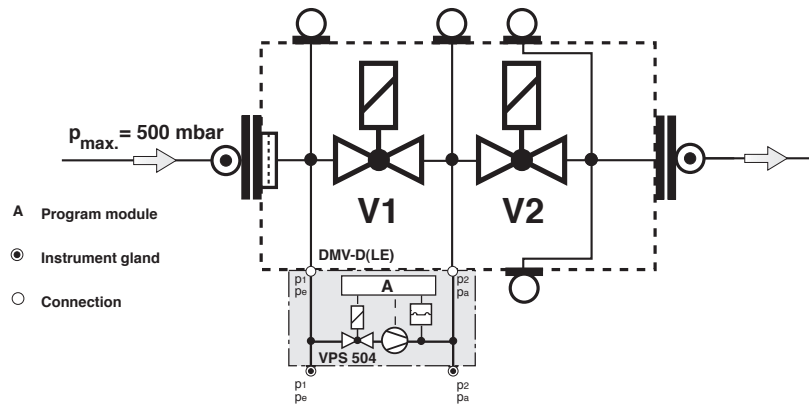

Release period t_F

Period which a VPS requires to perform a complete operation procedure.

The release period of the VPS 504 depends on **test volume and input pressure**:

Test volume V_{Test} :

$$\left. \begin{array}{l} V_{Test} < 1.5 \text{ l} \\ p_e > 20 - 500 \text{ mbar} \end{array} \right\} t_F \approx 10 \text{ s}$$

$$\left. \begin{array}{l} V_{Test} > 1.5 \text{ l} \\ p_e > 20 \text{ mbar} \end{array} \right\} t_F > 10 \text{ s}$$

t_F max. $\approx 26 \text{ s}$

Test period P_t

Pumping time of motor pump.

Test volume V_{Test}

Volume between V1 output-side and V2 input-side and the intermediate tube pieces.

$$V_{Test \text{ max. / VPS 504}} = 4 \text{ l}$$

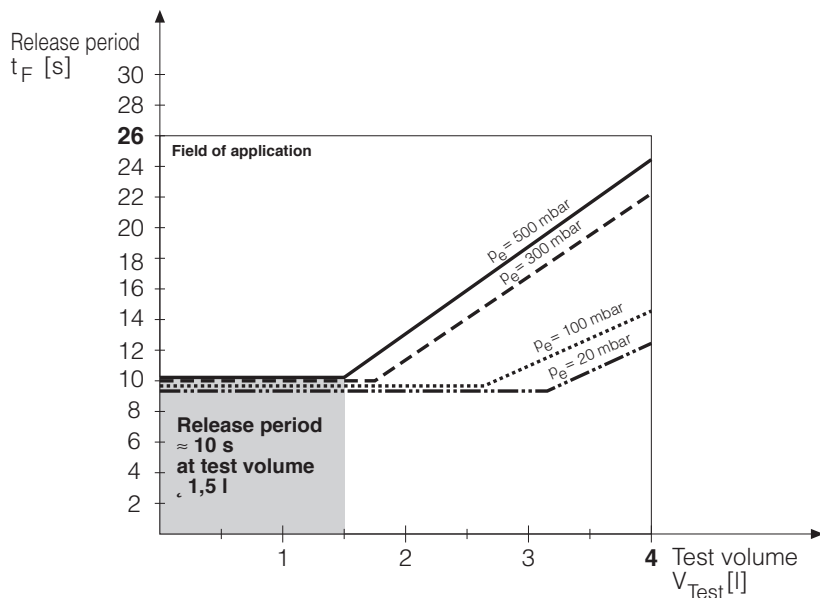

Program sequence

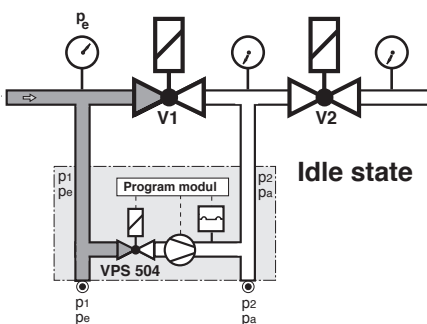

Idle state

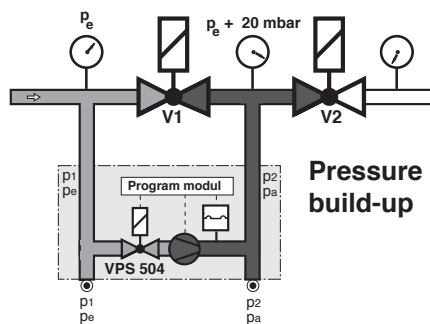

Pressure build-up

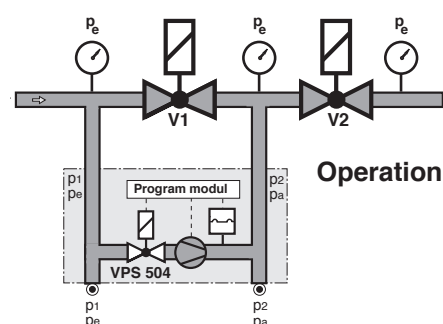

Operation

Idle state: Valves 1 and 2 are closed.

Pressure build-up: The internal motor pump increases the gas pressure in the test section by approx. 20 mbar compared to the input-side pressure applied to valve V1.

During the test period, the installed differential pressure switch monitors the test section for leakage. If the test pressure is attained, the motor pump is switched off (end of test period). The release time (10-26 s) depends on the

test volume (max. 4.0 l) and input pressure (max. 500 mbar). If the test section is tight, the contact is released to the automatic burner control after max. 26 s - the yellow signal lamp lights up.

If the test section is leaky or if the pressure increase by + 20 mbar is not attained during the test period (max. 26 s), the VPS 504 switches to fault. The red signal lamp lights as long as the contact release by the regulator or thermostat is present (heat requirement).

If there is a short power failure during the test or burner operation, the test is started again automatically.

If the pumping time < approx. 10s, the pressure difference between the testing system and the inlet pressure is balanced after pumping is finished.

Operation: The internal valve of the VPS 504 is closed.

Program flowchart

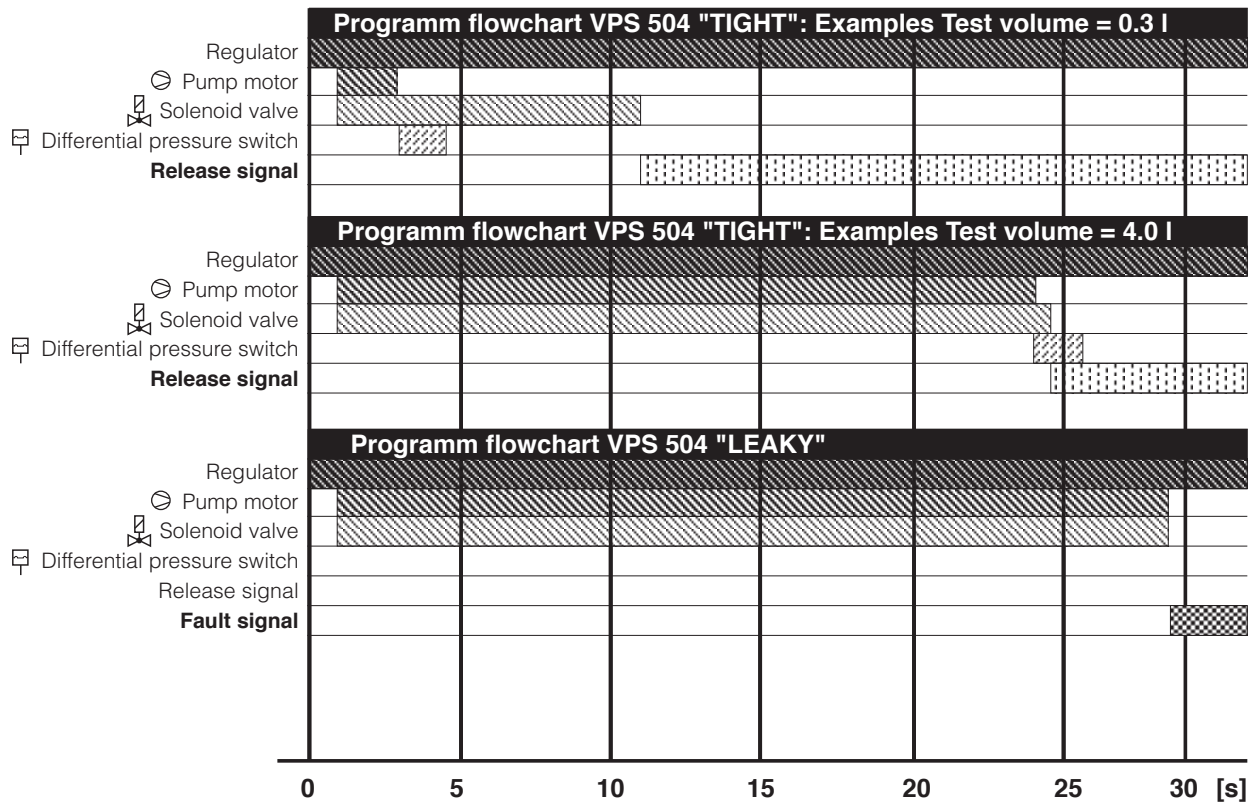

Electrical connection VPS 504 Series 01

The VPS 504 Series 01 is connected in series between temperature regulator and automatic burner control via a 7-pole connector. Connector pin assignment between burner and boiler is performed as per DIN 4791. For pin assignment, refer to connection diagram.

If the heat generator is wired as per DIN 4791, no boiler- or burner-side rewiring is necessary for electrical connection.

The burner female connector is connected with the cable-to-cable male connector of VPS 504 Series 01.

The female connector VPS 504 Series 01 is connected with the cable-to-cable male connector of the heat generator.

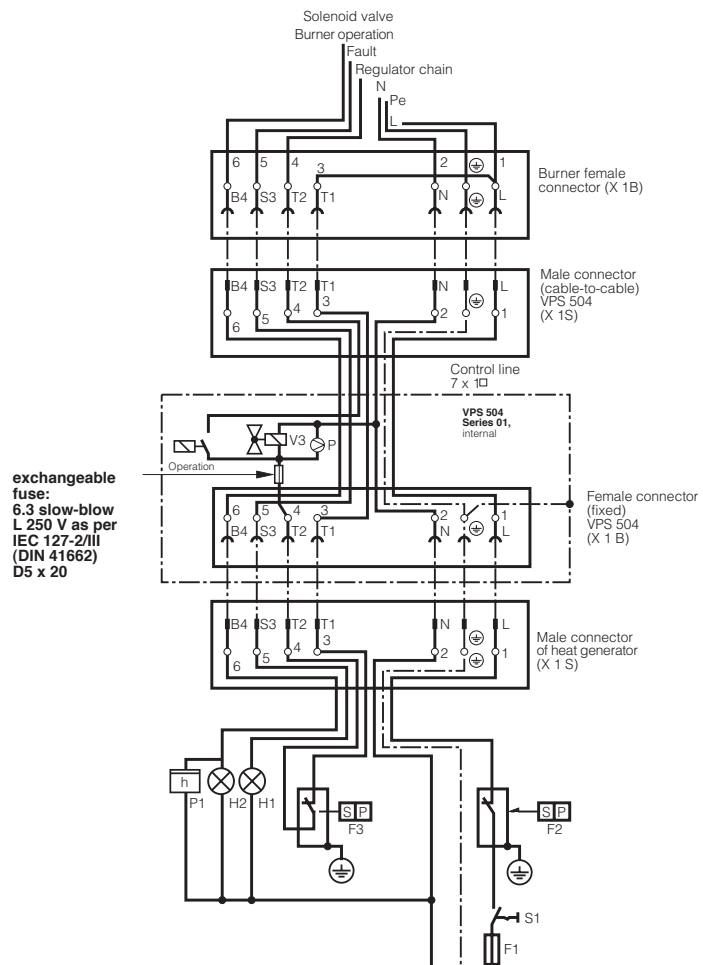

- F1 Fuse
- F2 Switch or limiter
- F3 Regulator
- H1 Fault signal
- H2 Operation signal
- P1 Operating hours counter
Stage 1
- S1 Switch
- X1B Female connection
- X1s Male connection

Electrical connection
VPS 504 Series 01 SSM
Group fault alarm

The electrical connection of VPS 504 Series 01 SSM is performed the same way as with the VPS 504 Series 01 (see page 5).

Additional switching characteristic of VPS 504 Series 01 SSM

If the test path is „untight“, the VPS switches to fault.

An additional relay in the VPS interrupts the burner fault line S3 between burner and heat generator. At the same time, voltage is applied from the heat generator to S3 line and the LED H1

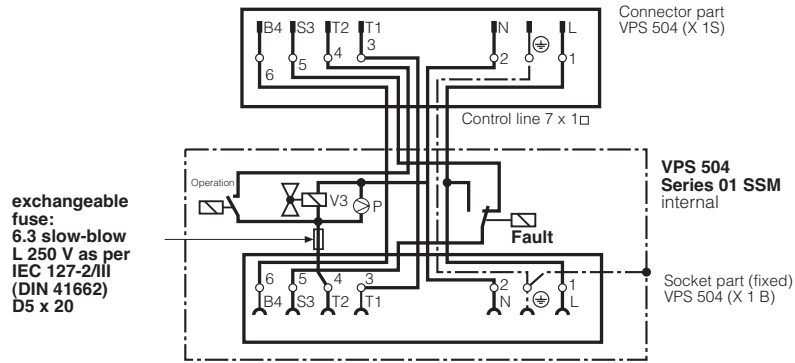

Electrical connection
VPS 504 Series 02

The VPS 504 Series 02 is connected in series between temperature regulator and automatic burner control via a 7-pole connector.

The boiler male connector is inserted into the female connector of VPS 504.

For pin assignment of female connector VPS 504 and heat generator male connector, refer to connection diagram.

Switching feature: No disconnection between operating voltage circuit and control circuit.

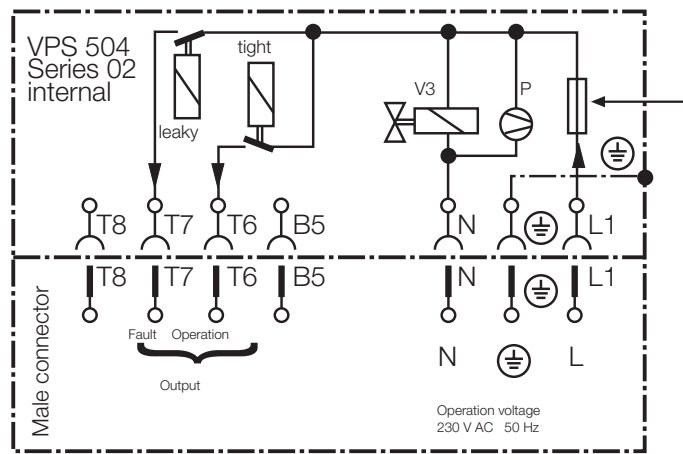

Electrical connection
VPS 504 Series 03

The electrical connection of VPS 504 Series 03 is performed as in VPS 504 Series 01.

Additional switching feature of VPS 504 Series 03

If a fault signal is existent on S3 (burner fault), the regulator chain is bridged to the burner via an additional relay in VPS 504 Series 03 and at the same time the operating voltage of VPS 504 Series 03 is interrupted.

After eliminating the burner fault, the valve proving system is restarted.

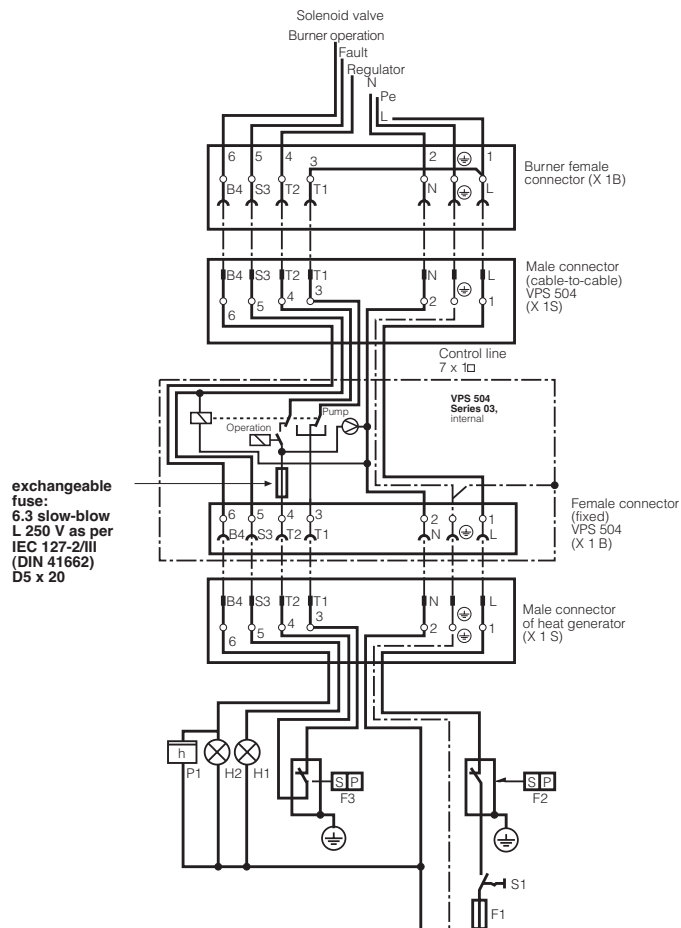

⚠ Only the fault signal coming from the automatic burner control of the burner may be connected to connection S3. If you do not observe this instruction, persons may be injured or objects may be damaged. Therefore, strictly keep to this instruction.

Electrical connection

VPS 504 Series 04

PG 13.5 cable duct and connection to screw terminals below cover in housing (see Dimensions VPS 504 S04).

Warning: Floating control room signal may only be used for signalling, never for burner release.

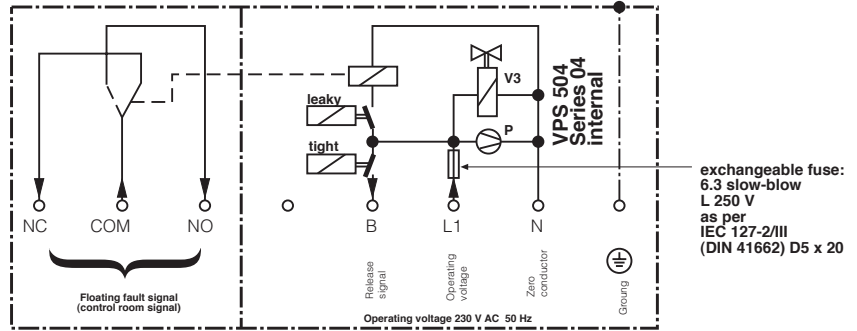

Electrical connection

VPS 504 Series 05

PG 13.5 cable duct and connection to screw terminals below cover in housing (see Dimensions VPS 504 S04).

Warning: Operating voltage range 20 V - 30 V DC. Refer to motor startup current!

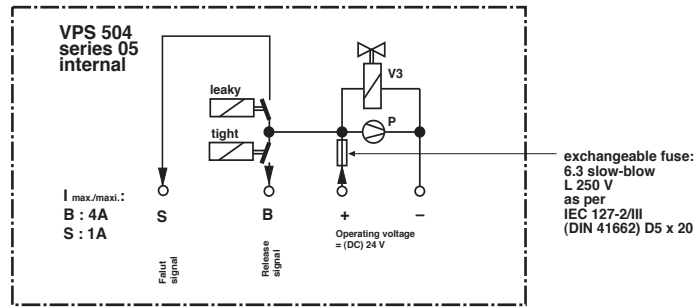

Test volume of DUNGS multiple actuators MB-D..., MB-ZR..., MB-VEF..., DMV-..., MBC-...

Type	Nominal diameter Rp/DN	Test volume [l]	Type	Nominal diameter Rp/DN	Test volume [l]
DMV-D(LE) 503/11	Rp 3/8	0.03 l	MB-D(LE) 403	Rp 3/8	0.04 l
DMV-D(LE) 507/11	Rp 3/4	0.10 l	MB-D(LE) 405	Rp 1/2	0.11 l
DMV-D(LE) 512/11	Rp 1 1/4	0.24 l	MB-D(LE) 407	Rp 3/4	0.11 l
DMV-D(LE) 520/11	Rp 2	0.24 l	MB-D(LE) 410	Rp 1	0.33 l
DMV-D(LE) 525/11	Rp 2	0.44 l	MB-D(LE) 412	Rp 1 1/4	0.33 l
DMV-D(LE) 5040/11	DN 40	0.38 l	MB-D(LE) 415	Rp 1 1/2	0.24 l
DMV-D(LE) 5050/11	DN 50	0.39 l	MB-D(LE) 420	Rp 2	0.24 l
DMV-D(LE) 5065/11	DN 65	0.69 l	MB-ZRD(LE) 405	Rp 1/2	0.11 l
DMV-D(LE) 5080/11	DN 80	1.47 l	MB-ZRD(LE) 407	Rp 3/4	0.11 l
DMV-D(LE) 5100/11	DN 100	2.28 l	MB-ZRD(LE) 410	Rp 1	0.33 l
DMV-D(LE) 5125/11	DN 125	3.56 l	MB-ZRD(LE) 412	Rp 1 1/4	0.33 l
DMV-1500-D	Rp 2	0,44 l	MB-ZRD(LE) 415	Rp 1 1/2	0.24 l
DMV-...(DLE) -65	DN 65	1,47 l	MB-ZRD(LE) 420	Rp 2	0.24 l
DMV-...(DLE) -80	DN 80	2,28 l	MB-VEF 407	Rp 3/4	0.11 l
DMV-...(DLE) -100	DN 100	3,55 l	MB-VEF 412	Rp 1 1/4	0.33 l
			MB-VEF 415	Rp 1 1/2	0.24 l
			MB-VEF 420	Rp 2	0.24 l
			MB-VEF 425	Rp 2	0.44 l
			MBC 300	Rp 3/4	0.05 l
			MBC 700	Rp 1 1/4	0.61 l
			MBC 1200	Rp 2	2.05 l
			MBC 1900	DN 65	1.47 l
			MBC 3100	DN 80	2.28 l
			MBC 5000	DN 100	3.55 l

Using the VPS 504 at DUNGS individual solenoid valves .../5

For mounting the VPS 504 to valves **Rp 1 1/2 to Rp 2**, the adapter kit, **Order No. 205 360** is required.

For mounting the VPS 504 to valves **DN 40 to DN 80**, the adapter kit, **Order No. 222 740** is required.

Determining test volume V_{Test}

1. Determine output-side volume of V1.
Refer to table for Rp 1/2 to DN 80.
2. Determine input-side volume of V2.
Refer to table for Rp 1/2 to DN 80.
3. Determine volume of intermediate tube piece 3.
Refer to table for Rp 1/2 to DN 80.

$$V_{\text{Test}} = \text{Volume}_{\text{Valve 1}} + \text{Volume}_{\text{Intermediate tube piece}} + \text{Volume}_{\text{Valve 2}}$$

$$V_{\text{Test}} = \text{Valve volume } \begin{matrix} \text{V1 output-side+} \\ \text{V2 input-side} \end{matrix} + \text{Volume of tube line}$$

Determining test volume V_{Test}

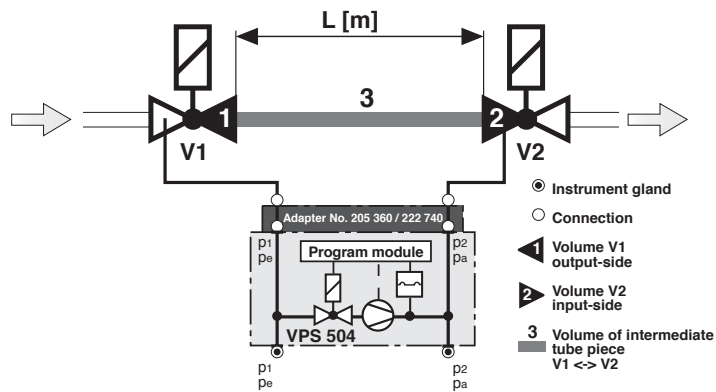

Determining test volume V_{Test} for DUNGS individual solenoid valves .../5

Nominal diameter Rp / DN	Valve volume [l]		Test volume [l] = Volume V1 _{output-side} + V2 _{input-side} + tube length							
	V1 _{output-side} Rp	V2 _{input-side} DN	0.5 m Rp DN		1.0 m Rp DN		1.5 m Rp DN		2.0 m Rp DN	
Rp 1/2	0.07 l		0.17 l		0.27 l		0.37 l		0.47 l	
Rp 3/4 (DN 20)	0.12 l		0.27 l		0.42 l		0.57 l		0.72 l	
Rp 1 (DN 25)	0.20 l		0.45 l		0.70 l		0.95 l		1.20 l	
Rp 1 1/2 / DN 40	0.50 l	0.70 l	1.10 l	1.35 l	1.70 l	2.00 l	2.80 l	2.65 l	2.80 l	3.30 l
Rp 2 / DN 50	0.90 l	1.20 l	1.90 l	2.20 l	2.90 l	3.20 l	3.90 l			
DN 65		2.00 l		3.70 l						
DN 80		3.80 l								

! The max. test volume of 4.0 l must not be exceeded.

Startup

1. Check test section for leaks after assembly.
2. Start test by using temperature regulator and/or restart or by pressing the reset button of VPS 504.

3. If the test section is tight

Depending on the length of the test section and the residual pressure applied, the pumping time is between 3 s and 26 s.

The release for the automatic burner control is then given after approx. 10 s at the earliest (at small test volumes and small input pressures) and after approx. 26 s at the latest (at large test volumes and large input pressures) - the yellow signal lamp lights up.

If the test section is leaky

The test pressure is not attained. The motor pump switches off, the red

fault lamp lights up. Switch-through to the automatic burner control does not take place.

Functional check

By opening a screw plug in test nipple p_2 (p_a) during test period (pumping time), leakage can be simulated and a function check can take place.

Setting

The VPS 504 must **not** be adjusted on site.

Assembly

Directly flange the VPS 504 laterally to the DUNGS multiple actuators (mounting is possible on left-hand or right-hand side) using two 10.5 x 2.25 O rings and four M4 x 16 self-tapping screws.

! If an exhaust gas valve is installed in the boiler, it must be open at the beginning of the test.

! In order to prevent functional and leakage problems, we recommend the use of solenoid valves as per EN 161 Class A and Class B.

! Insufficiently shielded frequency converters could cause faults in the VPS due to network disturbances. Make provisions for sufficient electrical shielding.

Dimensions [mm]
VPS 504 Series 01, Series 03

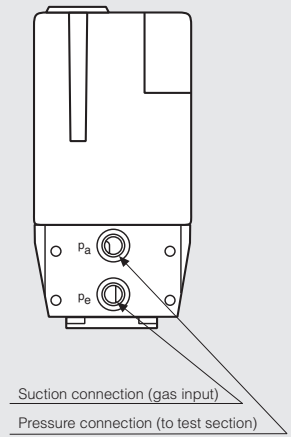
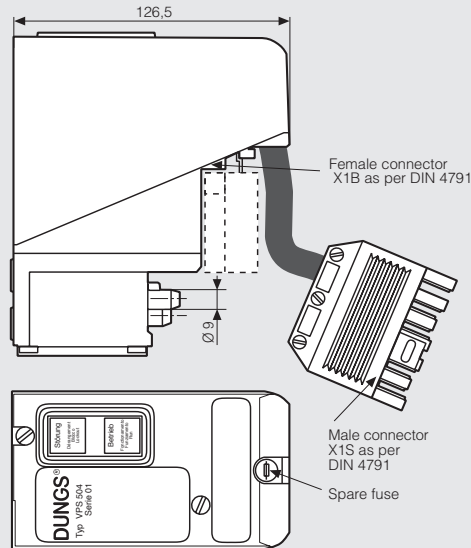
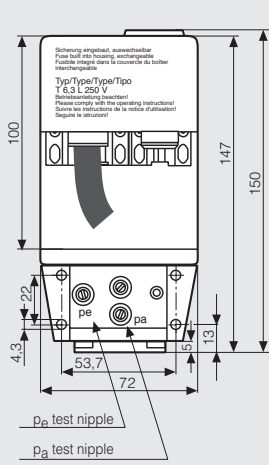

Dimensions [mm]
VPS 504 Series 02

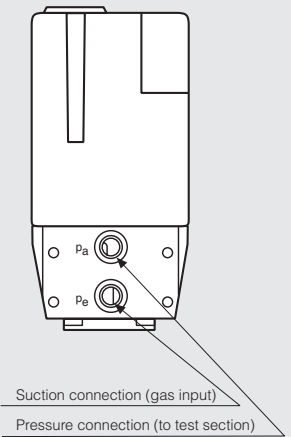
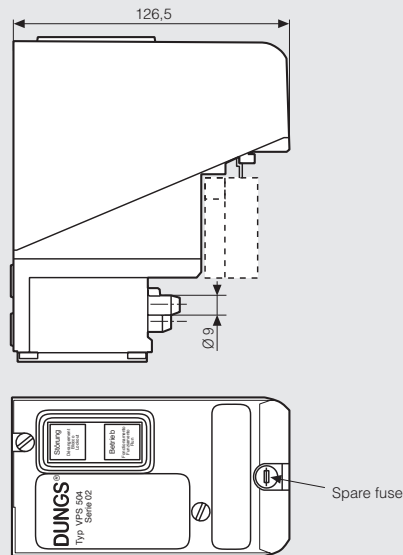
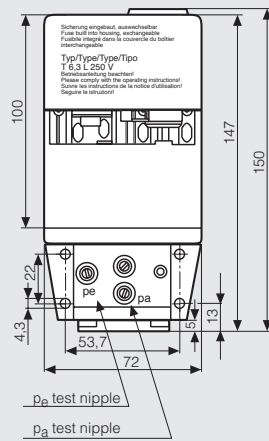

Dimensions [mm]
VPS 504 Series 04, 05

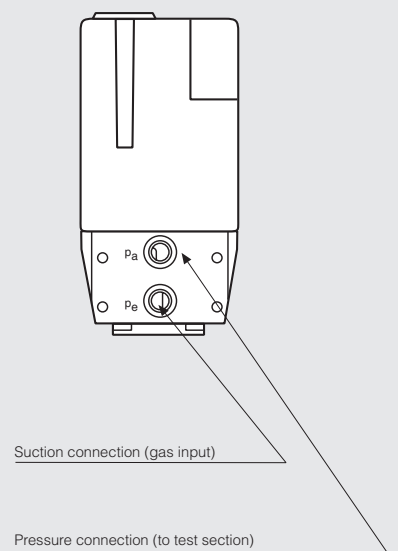
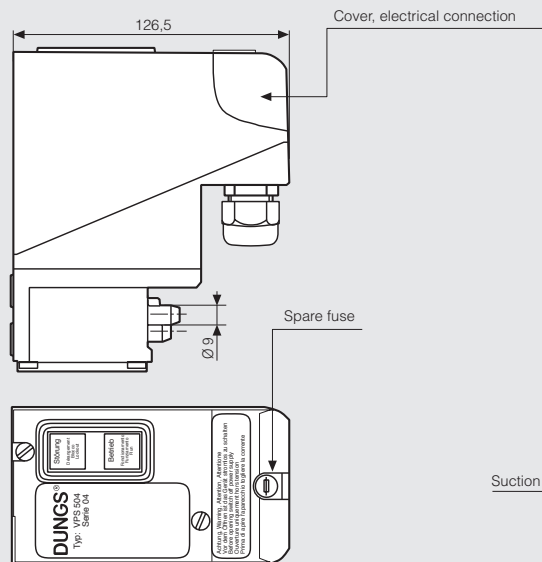
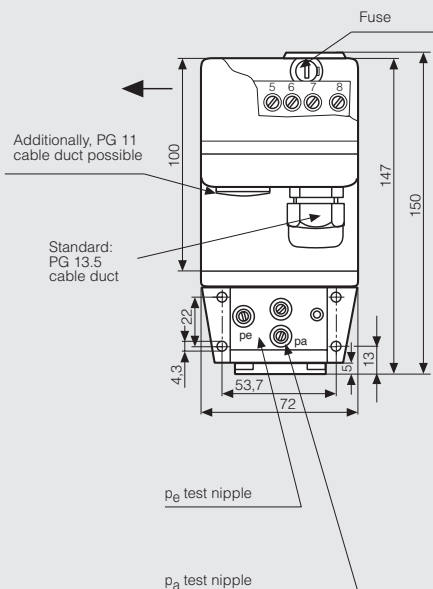

**Valve testing system VPS 504
for multiple actuators**

DUNGS®

VPS 504 type overview / accessories / order data

Version VPS 504 Series ...		24 VDC	230 V 50 Hz	220 V 60 Hz	120 V 60 Hz	110 V 50 Hz
VPS 504 Series 01 7-pole plug connection Wiring as per DIN 4791 IP 40 degree of protection Group fault alarm Group fault alarm	Cable length: 0.30 m Cable length: 0.85 m Cable length: 1.50 m Cable length: 2.00 m Cable length: 0.85 m Cable length: 2.00 m		219 873 219 874 219 875 219 876 227 462 227 527	222 390		223 464
VPS 504 Series 02 7-pole plug connection Free connection IP 40 degree of protection Liquefied gas model	with male connector without male connector with male connector	225 481	219 877 219 878 226 315	222 389		223 463
VPS 504 Series 03 7-pole plug connection Wiring as per DIN 4791 IP 40 degree of protection	Cable length: 0.30 m Cable length: 1.50 m		219 879 223 590			
VPS 504 Series 04 Connection to screw terminals PG 13.5 cable duct Additionally, PG 11 possible Floating fault signal (control room signal) IP 54 degree of protection Liquefied gas model			219 881 226 316	222 388 242 874	223 426 242 875	221 327 242 876
VPS 504 Series 05	Gasmotors (CSA)	224 983				
VPS 504 Series 06	U _L , FM, CSA				221 073	
Accessories/spare parts Adapter kit VPS 504 for solenoid valves up to Rp 2 Adapter kit VPS 504 for solenoid valves from DN 40 to DN 80 7-pole male connector, 2 cable inputs with strain relief (series 02) 7-pole male connector, 4 cable inputs with PG 11 (series 02) 7-pole male connector, 4 cable inputs with strain relief (series 02) Mounting kit (4 x M4 x 16,2, 2 x O-Ring, 2 x filter insert) Appliance fuse link (5 pieces) Spare parts set VPS filter			205 360 222 740 231 807 231 808 231 809 221 503 231 780 243 801			

We reserve the right to make any changes in the interest of technical progress.

Head Offices and Factory
Karl Dungs GmbH & Co. KG
Siemensstraße 6-10
D-73660 Urbach, Germany
Telephone +49 (0)7181-804-0
Fax +49 (0)7181-804-166

Postal address
Karl Dungs GmbH & Co. KG
Postfach 12 29
D-73602 Schorndorf, Germany
e-mail info@dungs.com
Internet www.dungs.com