

Dimensions and connection plans F-Series

- F-Series standard
- Optional equipment, back sucking system, hand-operated (code R1)
- Optional equipment, back sucking system, pneumatical (code R2)

Dimensions ALMATEC F 10 and F 20

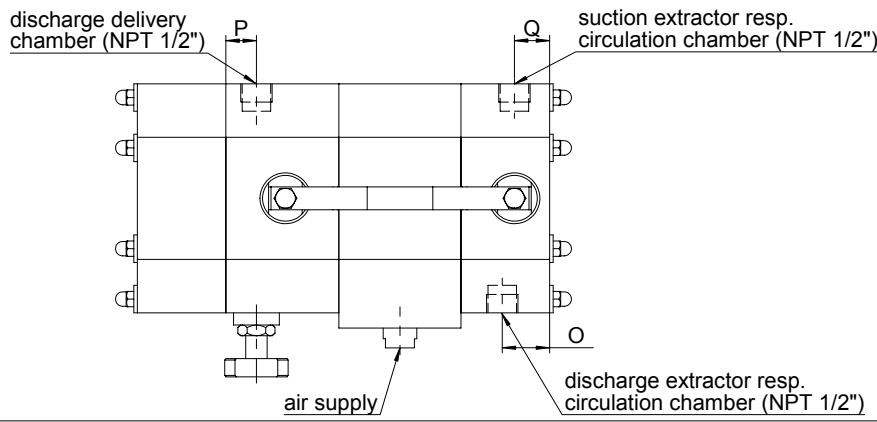
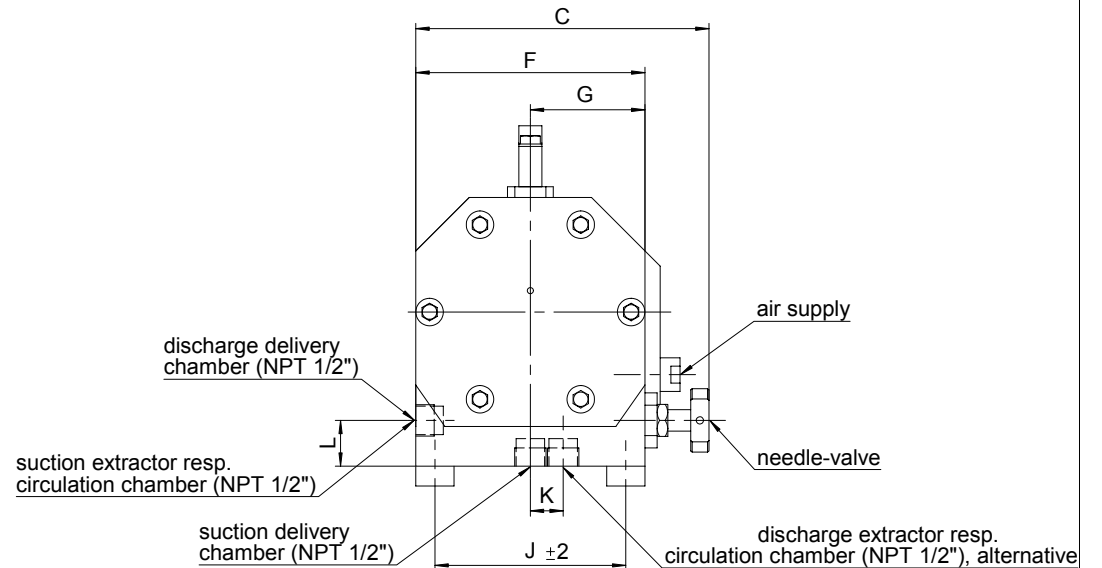
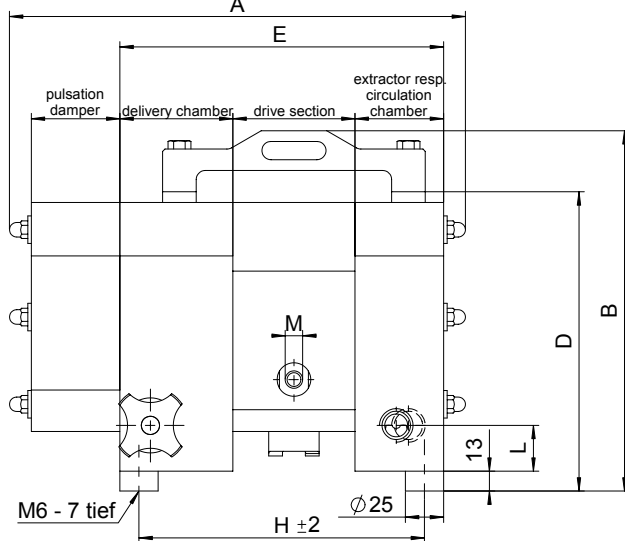
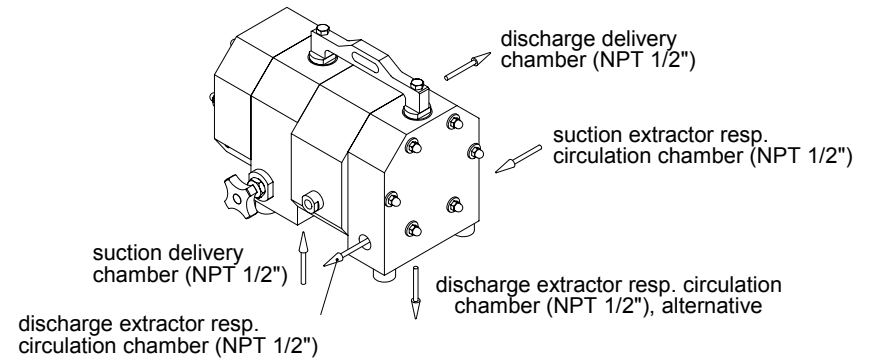
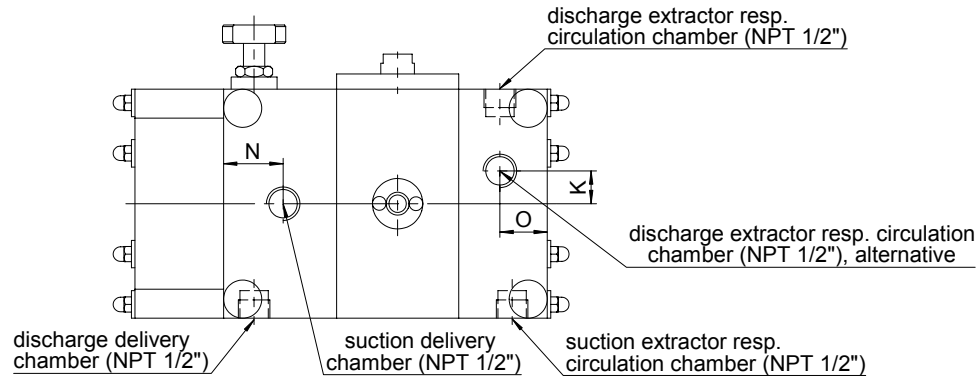

	A	B	C	D	E	F	G	H	J	K	L	M	N	O	P	Q
F 10	230	191	148	151	164	106	53	139	81	20	28	R 1/8"	33	30	19	23
F 20	300	236	192	196	212	150	75	187	125	21,5	30	R 1/4"	39	31	20	23

ALMATEC®

ALMATEC Maschinenbau GmbH
 Carl-Friedrich-Gauß-Str. 5
 D-47475 Kamp-Lintfort

Telefon (0 28 42) 9 61 - 0
 Telefax (0 28 42) 9 61 - 40
<http://www.almatec.de>
 e-mail: info@almatec.de

ALMATEC®

F - Series

Manual back sucking system (Code R1)

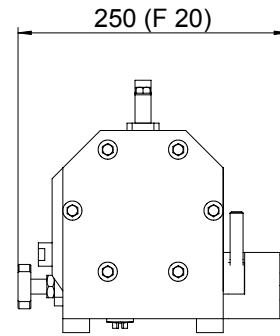

1)

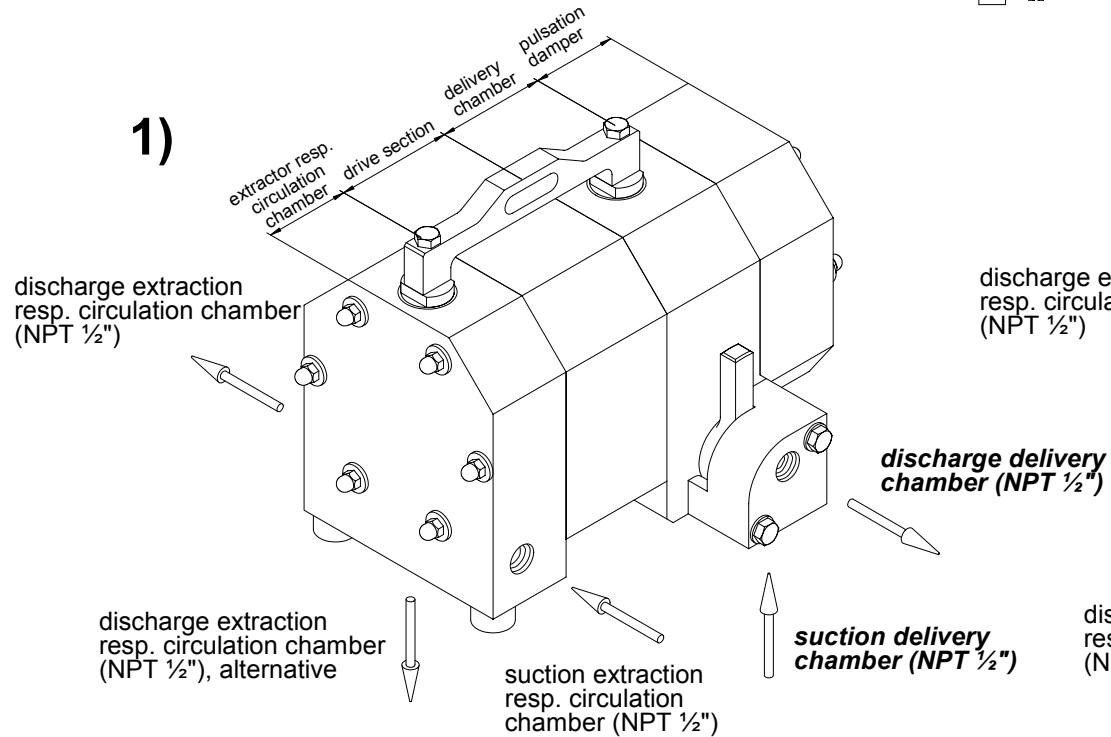

2)

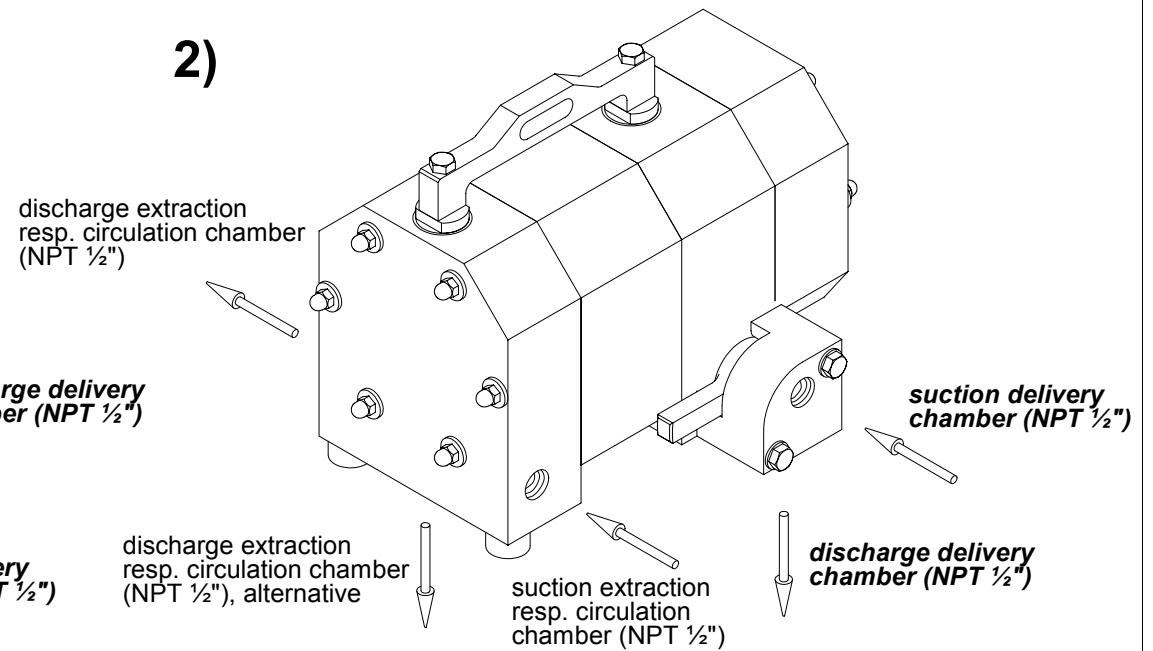

F - Series

Pneumatic back sucking system (Code R2)

1)

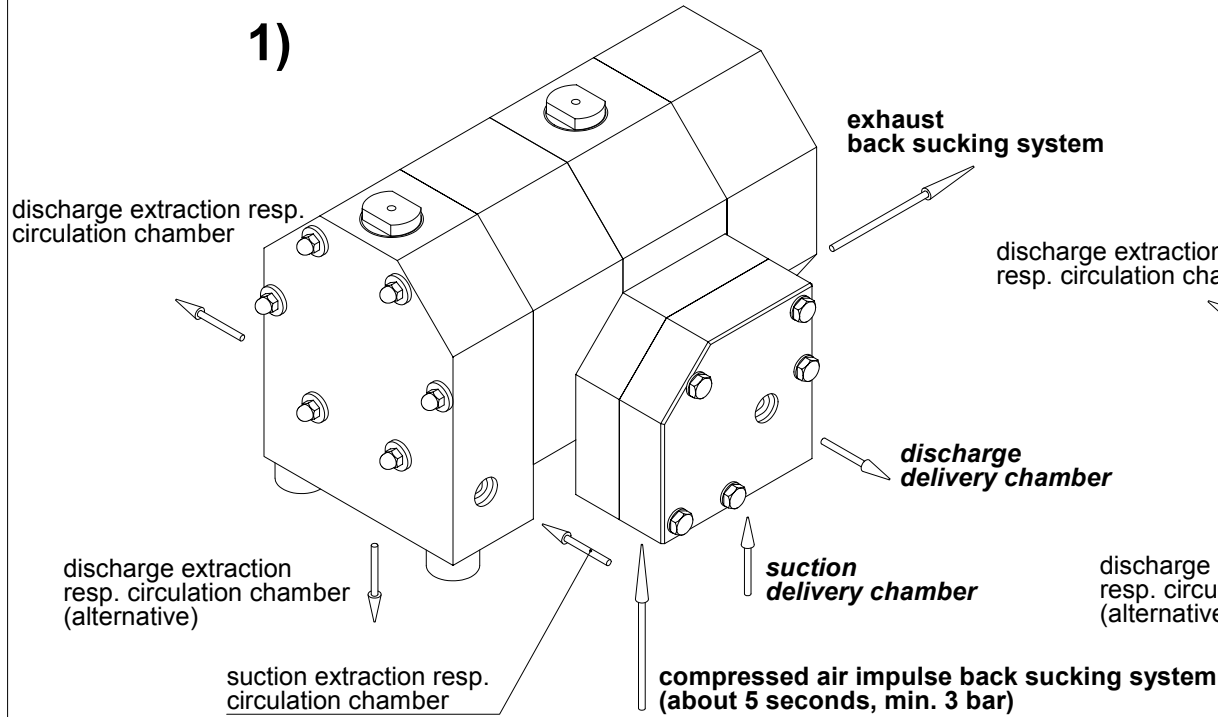

2)

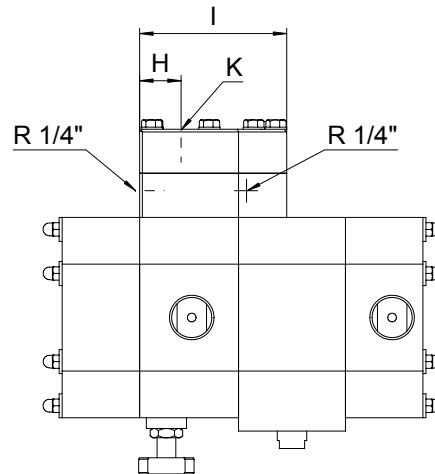
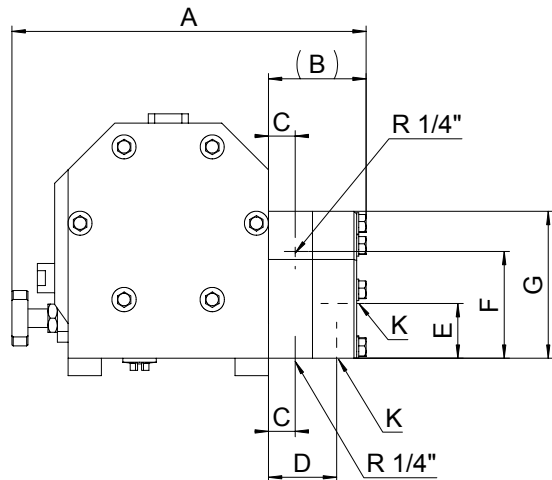
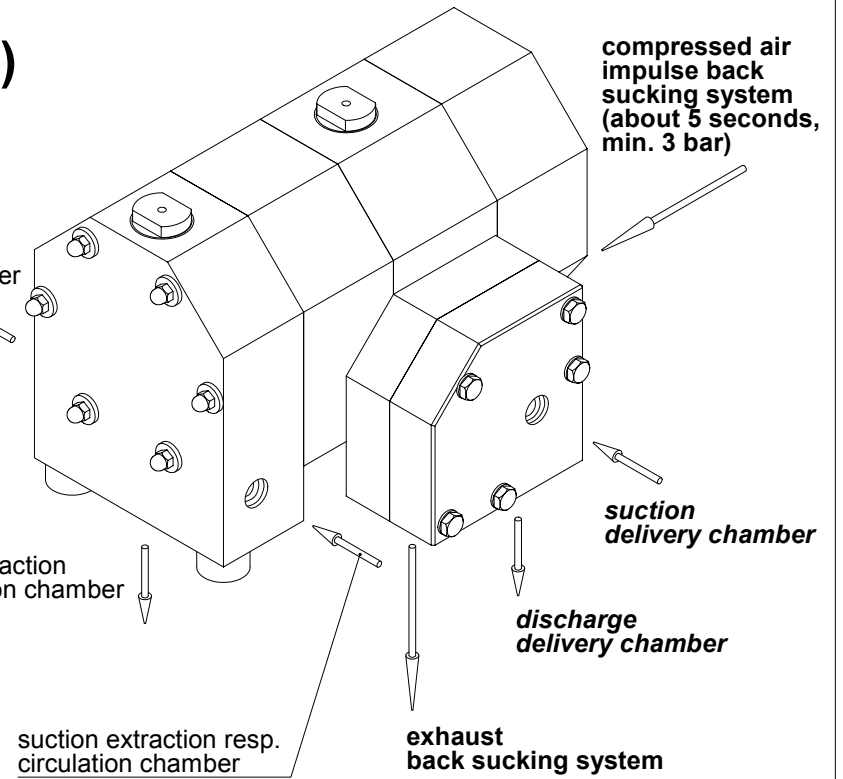

	A	B	C	D	E	F	G	H	I	K
F 20	266	74	20	51	41	80	110	31	110	NPT 1/2"