



SONDERMANN
PUMPEN + FILTER GMBH & Co. KG

OPERATION INSTRUCTION

**Magnetically Coupled Centrifugal Pumps
of Types RM 1**

Made of PP, PVDF or stainless steel



SONDERMANN PUMPEN + FILTER GMBH & Co. KG, D-51149 KÖLN

Tel.: +49-2203-9304-0, Fax: +49-2203-9394-48, E-Mail: info@sondermann-pumpen.de

EG-Konformitätserklärung

EC Declaration of Conformity

Déclaration de Conformité CE

Hiermit erklären wir, dass die **SONDERMANN magnetisch gekuppelten Kreiselpumpen** in den gelieferten Werkstoffen und Ausführungen, folgenden einschlägigen Bestimmungen entsprechen:

We herewith confirm that the **SONDERMANN magnetically coupled centrifugal pumps** in the supplied materials and versions corresponds to the following EC-rules:

Nous confirmons que **les pompes centrifuges à accouplement magnétique SONDERMANN**, livrées en matériaux et versions différents, sont conformes aux dispositions réglementaires suivantes:

(1) EG-Richtlinie Maschinen 98/37/CE	EC Machinery Directive 98/37/CE	Directive CE Machines 98/37/CE
(2) EG-Niederspannungsrichtlinie 2006/95/EG	EC Low Voltage Directive 2006/95/EG	Directive CE Bas Voltages 2006/95/EG

Köln, 01.08.2007

S O N D E R M A N N
PUMPEN + FILTER GMBH & Co. KG



Klaus Hahn
Geschäftsführer

CONTENTS

1	General information	6
1.1	Fields of application:	6
1.2	Technical data	6
2	Safety	7
2.1	Marking of safety instructions in this operating manual	7
2.2	Qualification and training of operating personnel	8
2.3	Hazards in the event of non-compliance with safety instructions	8
2.4	Working in compliance with safety regulations	8
2.5	Safety instructions relevant for operating the pump	8
2.6	Safety instructions relevant for maintenance, inspection and assembly work	29
2.7	Unauthorized alterations and production of spare parts	29
2.8	Inadmissible modes of operation	29
3	Transportation and storage	29
3.1	Transportation	29
3.2	Storage	29
4	Functional characteristics and accessories	29
4.1	General description	29
4.2	Constructional design	30
5	Mounting and installation	30
5.1	Mounting	11
5.2	Hose and pipe lines	11
5.3	Electrical connection	11
5.4	Check sense of rotation	32
6	Starting and shut-down procedures	13
6.1	Preparations for starting	13
6.2	Starting the pump	13
6.3	Operation	13
6.4	Shut-down procedure	13
6.5	Waste disposal	14
7	Service and maintenance	14
7.1	General information	14
7.2	Preventive maintenance	14
7.3	Dismantling the pump head	15

7.4	Assembling the pump head.....	16
8	Troubleshooting.....	16
9	Spare parts	18
9.1	Exploded view	18
9.2	Spare parts list	39
10	Appendix.....	20
10.1	Dimensioned drawing	20
10.2	Technical specification	20
10.3	Performance charts.....	21
10.4	Labour protection and accident prevention	22
10.5	Declaration of harmlessness.....	23

1 General information

The pump may only be used in the range of applications authorized by the manufacturer. In case of modified operating conditions, please consult your pump's supplier and / or the manufacturer.

1.1 Fields of application:

- Pumping low-viscosity liquids resembling water.
- Pumping of acids, bases and others.
- Pumping of gaseous fluids.
- Any use other than the authorized one as well as any conversion of the pump is not permitted.

CAUTION!

Make sure that the materials of which the pump is made, are resistant to the fluids delivered.

Ask your pump's supplier or the manufacturer for the respective chemical resistance list.

- If you deliver crystallising fluids, make sure that the fluid does not crystallise within the pump. Should this happen, carefully rinse off all parts being in contact with the fluid once the pump has been shut off.

NOTE

Disassembly of the pump will cancel the right to all warranty claims!

1.2 Power ratings

The nameplate on the pump not only specifies its model type but also its operating data and serial number. Please indicate all these data when inquiring about an issue, reordering parts and especially when ordering spare parts. For further information, contact your pump's supplier or the manufacturer.

1.2 Technical data

(See also appendix)

Max. volume flow	see the nameplate
Max. delivery head	see the nameplate
Made of	PP, PVDF, stainless steel, ceramics, FKM, EPDM, or FEP
Supply voltage	see the nameplate
Motor capacity	600W
Current rating: A	see the nameplate
Sense of rotation	clockwise, seen from the pump towards the motor
Speed	2.850 rpm
Protection class	IP 55
Weight	PP = 2,7 kg PVDF = 3,2 kg Edelstahl = 3,4 kg
Max. admissible temperature of fluid delivered	
PP	80°C
PVDF	95°C
Stainless steel	95°C
Maximum system pressure at 20°C	
PP	1,0 bar
PVDF	2,0 bar
Stainless steel	8,0 bar

NOTE

To find out the maximum admissible temperature of the fluid delivered, check out the materials of which the pump is made and which are indicated on the nameplate or the delivery note.

The letters written on the nameplate are to be read as follows:

- PP = glass-fibre reinforced polypropylene
- PVDF = polyvinylidene fluoride
- VA = stainless steel
- K = oxide ceramic
- G = PTFE graphite
- V = gasket*)
- K = ceramic sleeve bearings
- K = ceramic starting ring of the pump housing
- K = ceramic centering shaft

***) materials available:**

- V = FKM (fluorinated rubber)
- E = EPDM (ethylene-propylene terpolymer)
- T = FEP (fluorinated ethylene propylene) coated

2 Safety

When installing, operating and maintaining the pump, the mounting and operating instructions detailed in the following should be strictly observed. Hence it is absolutely necessary that prior to assembling and starting the pump, the responsible installation personnel and/or users carefully read these operating instructions. Make sure that they are always available wherever the pump is used.

Not only the safety instructions detailed in this Safety chapter are to be observed but also the specific safety instructions provided in the following chapters.

2.1 Marking of safety instructions in this operating manual

Safety instructions given in this manual and non-compliance with which could be injurious to human beings, are identified by the general



safety sign
acc. to German DIN 4844-W9 standard.

Warnings of electricity are identified by the specific



safety sign
acc. to German DIN 4844-W standard.

Safety instructions non-compliance with which would give rise to malfunctions of the equipment are identified by

CAUTION!

Signs and labels affixed to the equipment such as

- arrows indicating the sense of rotation,
- symbols indicating fluid connections,
- warnings to protect the pump from dry-running,

must be strictly observed and always kept legible.

2.2 Qualification and training of operating personnel

All personnel responsible for operation, maintenance, inspection and assembly of the pump must be adequately qualified. Scope of responsibility and supervision of the personnel must be exactly defined by the plant operator. If staff members do not have the necessary knowledge, they should be trained and instructed accordingly. If necessary, the pump manufacturer or supplier will hold this training on behalf of the plant operator. The operator should also make sure that all operating instructions are fully understood by all personnel.

2.3 Hazards in the event of non-compliance with safety instructions

Non-compliance with safety instructions may produce a risk to personal life and health as well as to the environment and the pump and may result in a loss of any right to claim damages.

Non-compliance may involve risks such as

- failure of important functions of the pump and/or the installation;
- failure of specified procedures of service and maintenance;
- exposure of persons to electrical, mechanical, magnetic and chemical hazards;
- endangering of the environment because of hazardous substances leaking.

2.4 Working in compliance with safety regulations

When operating the pump, make sure to observe the safety instructions contained in this manual as well as the relevant national accident prevention regulations and any other service and safety instructions issued by the plant operator.

2.5 Safety instructions relevant for operating the pump

- If hot or cold machine components create any risk, they must be guarded against accidental contact.
- Guards for moving parts must not be removed from the equipment during operation.
- Hazardous (i. e. toxic, hot) fluids must be drained off to prevent any risk to persons or the environment. Statutory regulations are to be complied with in any case.
- Any hazard resulting from electricity should be ruled out completely. (For details see the German VDE specifications and the bye-laws of your local power supply utilities, for example.)

2.6 Safety instructions relevant for maintenance, inspection and assembly work

It shall be the plant operator's responsibility to ensure that all maintenance, inspection and assembly work is performed by authorized and qualified personnel who have adequately familiarized themselves with the subject matter by studying this manual in detail. Any work on the equipment shall only be performed when it is at a standstill. Make sure to strictly follow the procedure for shutting down the equipment prescribed in this manual.

Pumps and pump units that deliver hazardous fluids must be decontaminated after use.

On completion of work all safety and protective guards must be re-installed and be fully operational again.

Prior to restarting the pump, make sure to follow the instructions detailed in the Starting chapter below.

2.7 Unauthorized alterations and production of spare parts

The user is not allowed to subject the pump to any modification unless agreed upon with the manufacturer. It is in the interest of your safety to use genuine spare parts and accessories authorized by the manufacturer. Use of other parts may exempt the manufacturer from any liability resulting thereof.

2.8 Inadmissible modes of operation

Operational reliability of this equipment is only guaranteed if it is used in the manner intended, i.e. in accordance with chapter 1, General information, of this manual. The limit values specified in the data sheet must not be exceeded under any circumstances.

3 Transportation and storage

3.1 Transportation

The pump leaves the manufacturer's production site in a ready-to-work state. In the event of damages occurring during and due to transportation, the forwarding agent has to make a factual statement. The equipment should always be transported according to good professional practice.

3.2 Storage

The pump has to be stored absolutely dry and be protected from any pollutants entering.

4 Functional characteristics and accessories

4.1 General description

Magnetically coupled centrifugal pumps of type RM are non-self-priming centrifugal pumps. They operate in horizontal position and are made of plastic in monobloc design. A magnetic coupling connects the pump to the motor and transmits the power of the motor to the impeller.

4.2 Constructional design

Housing, impeller, impeller magnet and rear casing are made of plastic. Standard pumps are equipped with centering shafts and bearings made of oxide ceramic. The rear casing hermetically seals the fluid from the ambient atmosphere. Because of magnetic power transmission, there is no need to mechanically seal the shaft. So, in contrast to mechanically or gland sealed pumps, leakages through worn shaft sealings are definitely ruled out.



This pump is magnetically coupled. So when handling permanent-magnet components during repair or maintenance work you are exposed to magnetic forces which might influence pacemakers, for example.

Keep your distance.

The pump housing parts are sealed by static O-rings. The impeller of the pump is a radial-flow wheel. Depending on the fluid delivered, each component of the pump is available in various materials.

NOTE

The materials used for the pump are specified on its nameplate or the delivery note.

Choice of materials:

depends of type, see nameplate

Pump housing and rear casing, impeller and impeller magnet coating	PP, PVDF or stainless steel
Centering shaft	oxide ceramic
Sleeve bearings	oxide ceramic PTFE graphite
Starting rings	oxide ceramic
Static O-ring seals	FKM, EPDM, FEP (FKM and FEP coated)

4.3 Accessories and optional equipment

Accessory components including hose connections, pilottherms, motor circuit-breakers and flow monitors, are available on request.

5 Mounting and installation

The pump should be installed at a place that allows easy access at any time. Make sure to keep to the following limit values:

Ambient temperature	-10°C to +40°C
Humidity of the air	max. 95% relative humidity, non-condensing

NOTE

In case of higher ambient temperatures, please contact your pump's supplier or the manufacturer.

5.1 Mounting

The pump is usually mounted in horizontal position, vertical position only upon request.

This pump is not self-priming and therefore requires a feed line.

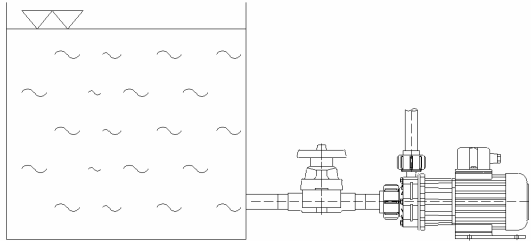

5.2 Hose and pipe lines

Make sure that the cross-sections of the pipelines fit the suction and discharge ports. All suction and discharge lines to the pump housing should be free of tensile stress. The weight of the hose and pipe lines must not rest on the housing.

CAUTION!

Do not install any quick-acting stop valves into the pipelines, since pressure jerks will damage the pump housing.

5.2.1 Suction line

- The suction line should be a tube or hose which will not deform by the resulting partial vacuum or by high temperatures.
- The suction line should be as short as possible. Make sure to mount it so that there will be no gas accumulation.
- When dimensioning pipelines, fittings etc., make sure to keep the flow resistances as low as possible.
- Flow velocity within the fitted suction line should not exceed the limit of 1m/s.

- For easy installation and removal of the pump, a shut-off valve (but no diaphragm valve) should be built into the suction line.

CAUTION!

Do not use the shut-off valve built into the suction line to adjust the delivery rate.

5.2.2 Discharge line

- Standard flow velocity within the discharge line is 3m/s.
- To adjust the flow rate, we recommend installing a control element to the discharge line.

5.3 Electrical connection



All electrical connections to the pump should be performed by experts only.

The electrical connections had to be done according to the following schematic (depends of the motor type; single phase or three phase, see nameplate):

Single phase motor:

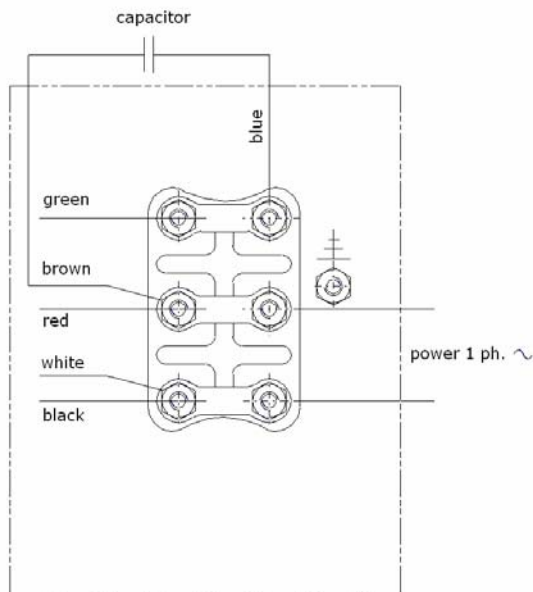

- All electrical connections and installations of additional protection devices should be performed by experts only and in accordance with the instructions of your local power supplier and/or the Association of German Electrotechnical Engineers VDE.
- The motor must be equipped with a motor circuit-breaker or a pilottherm to protect it from overloading.

NOTE

Motor protection devices are available with the pump's manufacturer.

- Make sure that the power supply has been cut off for at least 5 minutes before you start working on the terminal box of the pump.
- Check out whether the power supply available corresponds to the data given on the nameplate.

Three phase motor:

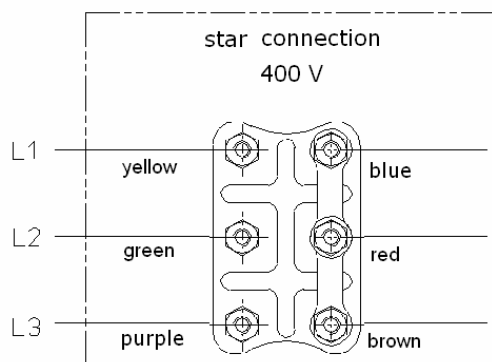
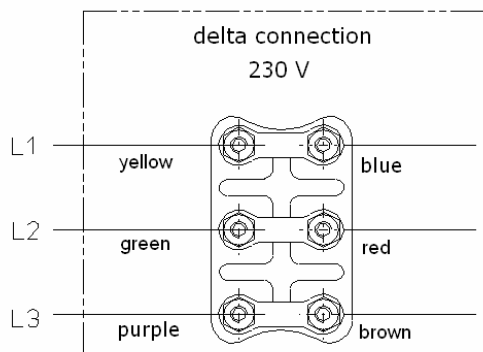

5.4 Check sense of rotation

CAUTION!

Do not check the sense of rotation before the pump is filled with fluid.

- Fill the pump housing and the suction line with water or the fluid to be delivered.
- Check the sense of rotation of the motor by switching it on and off in immediate succession. The sense of rotation must be in accordance with the arrow figuring on the pump. Slip a soft material, such as a paper strip, into the slits of the motor skirt to determine the sense of rotation

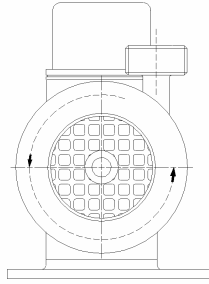

- Mind the sense of rotation indicated by an arrow on the pump and verify it after installation.

6 Starting and shut-down procedures

6.1 Preparations for starting

Always wear protective clothing.

- Fill the pump housing and the suction line with water or the fluid to be delivered.

CAUTION!

Avoid any dry-running of the pump!

NOTE

We recommend installing dry-running protection devices such as flow monitors, contact manometers, differential pressure switches or level controllers.

- Tighten all screwed connections.
- Entirely open all valves of the suction line.

6.2 Starting the pump

- Switch on the motor.
- Check the sense of rotation.

- Adjust the operating point by slowly opening the shut-off valve of the discharge line. If there is no shut-off valve installed to the discharge line, the operating point is automatically adjusted in accordance with the characteristic curve of the pump.

CAUTION!

Do not run the pump with the discharge line closed for a longer period of time. This may result in heating up the fluid inside the pump housing and damaging interior components of the pump.

CAUTION!

Always protect the pump from coarse impurities and magnetisable metal particles within the fluid delivered.

6.3 Operation

If the motor-circuit breaker switched off the pump motor, proceed as follows:

- Before switching on the motor again, check whether the impeller turns readily.
- Make sure that the suction line and the pump housing are filled with fluid.
- Switch on the motor.

If the pump delivers for a short period of time only and then stops pumping, the magnetic coupling has been disengaged. Proceed as described in chapter 8, Troubleshooting, below.

6.4 Shut-down procedure

- Switch off the motor.
- Close all valves.
- In case some fluid remains within the pump, secure the shut-off valves to prevent an accidental opening.

- If the pump is not to be used for some time, carefully rinse it off with a clean and neutral liquid. This is to prevent remaining fluid from depositing within the pump and the sleeve bearings.
- If the pump is shut down for repair or maintenance work, lock the driving unit so that it cannot be switched on. Before dismantling the pump, close the suction and the discharge lines and empty the pump under controlled conditions.
Secure all valves to prevent an accidental opening.
Wear protective clothing.

6.5 Waste disposal

This product as a whole as well as parts of it should be disposed of in an environmentally safe way.

CAUTION!

Please comply with the respective regulations that are currently in force at your place (especially with regard to electronic scrap).

7 Service and maintenance

7.1 General information

This pump is designed for continuous operation and does not require specific maintenance.

7.2 Preventive maintenance

- Although bearings, centering shaft and starting rings are designed for continuous operation, they should be periodically inspected for deposits.
- If dirty, silty or crystallising fluids are delivered, the pump should be inspected more often and cleaned, if necessary.
- Check the static sealings in regular intervals and replace them, if necessary.
- If not only wear parts are replaced, but also repair work is to be done, this should be performed by an expert only. Inappropriate service and maintenance work often results in a waste of money.

CAUTION!

When assembling or disassembling the pump, make sure that there are no magnetisable metal particles in the working area.



When the complete head of the pump is assembled or disassembled, magnetic forces can cause serious injury.

7.3 Dismantling the pump head

1. Loosen the 6 screws (901.1) of the pump housing. (101)

Required tool: open-end or ring spanner of size 10

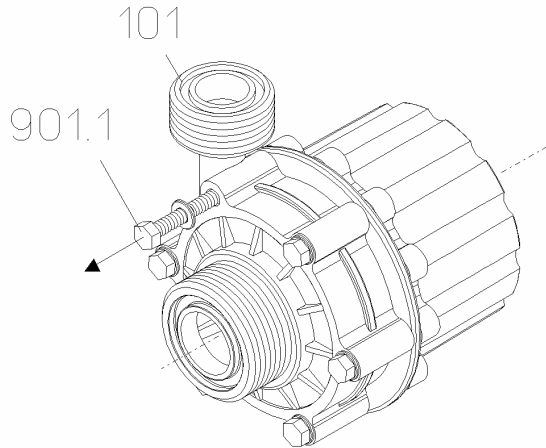

2. Take the pump head (001) from lantern (113).

No tools required.

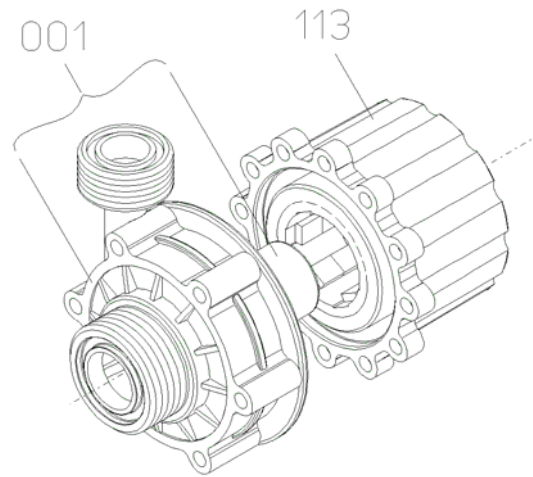

3. Take the pump housing (101) off the rear casing (161). Pull the impeller with the inner magnet (847.2) and the centering shaft (211) out of the housing

No tools required.

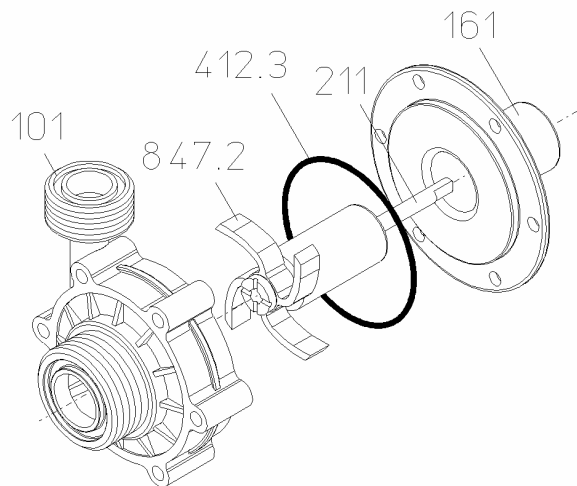

4. Take the starting ring (314.1) off the pump housing (101).

Required tool: centering shaft (211).

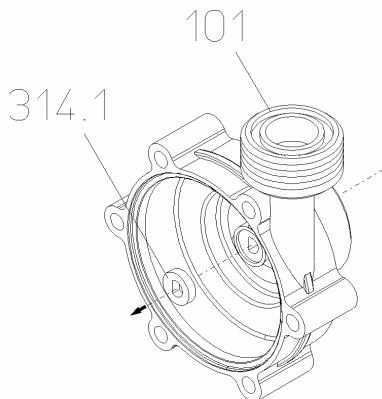

5. Take the starting ring (314.2) off the rear casing (161).

Required tool: centering shaft (211).

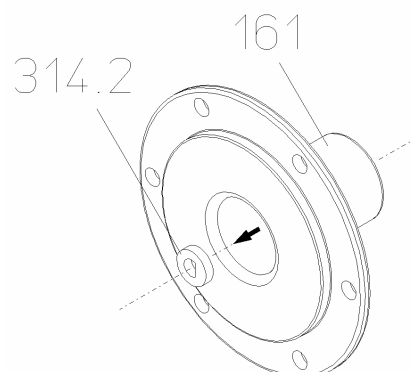

7.4 Assembling the pump head

To assemble the pump head reverse steps 1 to 5 described above.

CAUTION!

Once the complete head of the pump has been assembled, the impeller (230) and the impeller magnet (847.1) should be sliding along the axis of the centering shaft (211).

8 Troubleshooting

Malfunction	Cause	Corrective action
The pump does not work after being switched on.	No voltage.	Test the voltage.
	Impurities in the pump housing.	Remove the impurities.
The magnetic coupling is disengaged.	The relative density and/or viscosity of the fluid is too high.	Reduce the delivery rate; use a stronger magnetic coupling and a more powerful motor. Reduce the impeller diameter.
	The pump was switched off, then switched on again before the rotor stopped completely.	Make sure that the rotor has stopped completely before you switch the pump on again.
	The impeller jams.	Clean all interior components.
The motor is overheating.	The ventilator cowl is clogged.	Clean the ventilator and the cowl.
	The motor is overloaded.	Exactly adjust the motor circuit-breaker. Use a more powerful motor.
	The motor is not sufficiently cooled by ambient air.	Provide a place of installation with better air circulation or ventilation.
The pump is running, but not delivering.	The suction line or pump housing is filled with air.	Vent the suction line and the housing.
	The suction or discharge line valves are closed.	Open the valves.

Too much flow noise.	Cavitation. Wrong sense of rotation.	Check the suction line. Increase the suction line diameter. Reduce the discharge line diameter. Cool down the fluid. Correct the sense of rotation.
The pump is not sucking.	There is no fluid in the pump nor in the suction line. Since the pump is non-self-priming, both the suction line and the pump housing must be filled with fluid.	Open the valve. Fill the suction line and housing with fluid (using a foot valve, if necessary).
The delivery rate is too low.	There is air in the pump. The suction and/or discharge line is clogged. Cavitation. Wrong sense of rotation. The valve is not fully opened.	Check the suction line and seal it. Clean the suction and discharge lines. Increase the suction line diameter. Correct the sense of rotation. Fully open the valve.
The delivery rate is too high.	Pump losses are less significant than presumed.	Reduce the flow rate within the discharge line.
There is a leakage between pump and motor.	The pump housing is damaged. The pump is damaged because of solids or dry-running.	Have the pump dismantled and repaired by an expert.

NOTE

If the pump runs dry, the inner magnet usually bonds with the rear casing. Because of the impeller rotation, the fluid remaining in the pump housing heats up and evaporates. As the resulting frictional heat cannot be removed, the plastic material of the casing plasticizes and bonds with the inner magnet by "friction bonding". So do not run the pump with the discharge or the suction line closed for a longer period of time. Once the pump has run dry, liquid will leak out of the bore hole of the lantern between pump and motor. This means that the bonding of the interior parts with each other has resulted in a leaky rear casing.

9 Spare parts

9.1 Exploded view

Drawing number: PUMA.01.Z.394.000

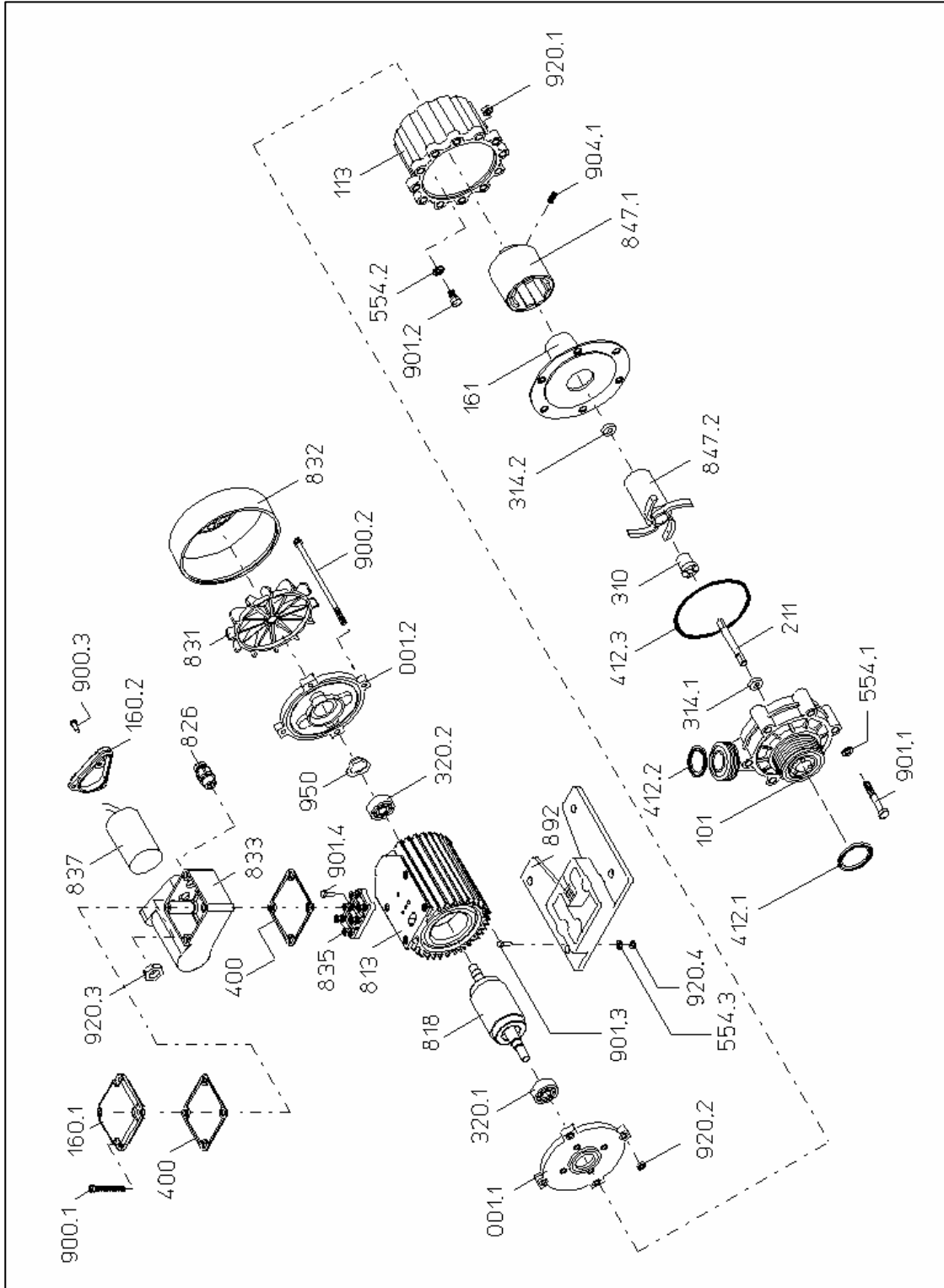

9.2 Spare parts list

Pos. Item.	Stück Qty	Bezeichnung	Description	Material	Abmessung Dimension	Bestell-Nr. Order No.
001.1	1	Lagerschild A-Seite	Endshield -drive end	PPS		110812
001.2	1	Lagerschild B-Seite	Endshield - non drive end	PPS		110803
101	1	Pumpengehäuse	Pumphousing	PP/PVDF		
113	1	Lateme	Lantern			110814
161	1	Spalttopf	Magnet housing	PP/PVDF		
211*	1	Zentrierwelle	Centering shaft	Keramik		110742
310*	1	Gleitlager	Bearing			
314.1*	1	Anlaufscheibe	Rear thrust washer	Keramik		110594
314.2*	1	Anlaufscheibe	Rear thrust washer	Keramik		110594
320.1*	1	Kugellager	Bearing		608	110806
320.2*	1	Kugellager	Bearing		608	110806
400	1	Klemmenkastendichtung	Terminal box seal			110811
412.1*	1	O-Ring Saugstutzen	O-ring intake		26 x 3,5	
412.2*	1	O-Ring Druckstutzen	O-ring ipressure joint		21 x 3,0	
412.3*	1	O-Ring Gehäuse	O-ring housing		66 x 2,0	
543.1	1	Distanzhülse	Distance piece			
543.2	1	Distanzhülse	Distance piece			
554.1	6	U-Scheibe	Washer	A 2	D 5,3	110821
554.2	4	U-Scheibe DIN 125	Washer DIN 125	A 2	D 5,3	110821
732	1	Kondensatorhalter	Subtage mount			
813	1	Motorgehäuse m. Wicklung	Motor casing with winding			
818	1	Rotor	Rotor			
826.1	1	Kabelverschraubung Pg 9	Wire screwing Pg 9			110809
826.2	1	Kabelverschraubung Pg 9	Wire screwing Pg 9			110809
831	1	Lüfterflügel	Motor fan blade			110802
832	1	Lüfterhaube	Motor fan blade cover			110805
833	1	Klemmenkasten	Terminal box			110810
835	1	Klemmbrett	Terminal board			110838
837	1	Kondensator	Condenser			
847.1	1	Antriebsmagnet	Drive magnet			111970
847.2*	1	Laufmagnet mit Laufrad	Impeller magnet w. impeller	PP/PVDF		
892	1	Montageplatte	Foot plate			110801
900.1	1	Zylinderkopfschraube	Cylinder screw			113390
900.2	4	Bundschraube	Glanged screw			110837
900.3	2	Zylinderkopfschraube	Cylinder screw	A 2		110643
901.1	6	Sechskantschraube	Hexagon head bolt	A 2		110822
901.2	4	Sechskantschraube	Hexagon screw			110813
904.1	1	Gewindestift	Threaded pin			113393
904.2	1	Gewindestift	Threaded pin			113392
914.1	2	Innensechskantschraube	Socket head screw			110836
914.2	2	Innensechskantschraube	Socket head screw			
920.1	4	Sechskantmutter	Hexagon nut			110815
920.2	4	Sechskantmutter	Hexagon nut			112507
920.3	1	Sechskantmutter	Hexagon nut			111231
930	1	Federring	Spring washer			113391
950	1	Wellfeder	Corrugated spring			110804

Items marked with an * are wear parts.

NOTE

When ordering spare parts, please indicate the item number of the part desired as well as the type of the pump, its serial number, motor capacity and drawing number.

10 Appendix

10.1 Dimensioned drawing and specifications of RM pumps of type 1

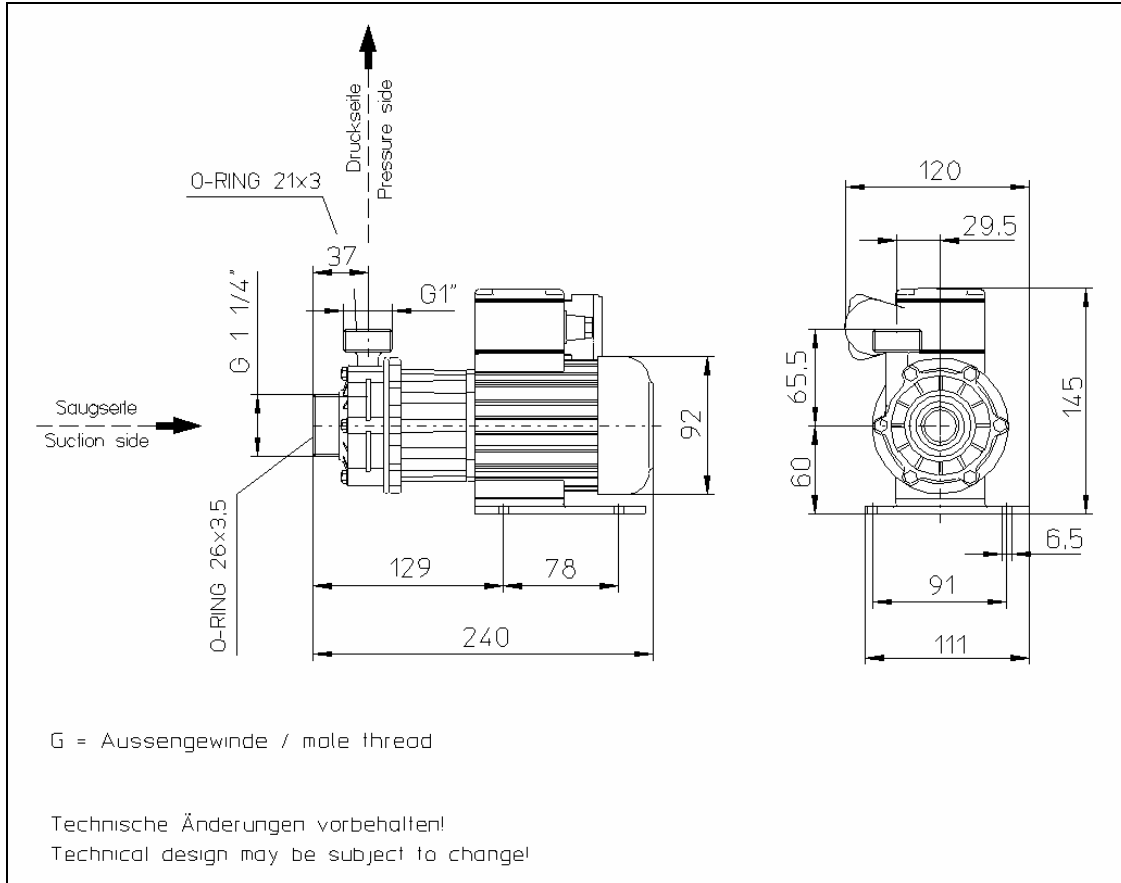

10.2 Technical specification

Type		2/20	3/20	5/30	7/30
max. delivery rate	[l/min]	15	20	30	30
max. delivery high	[m WS]	1,7	2,8	4,9	7,1
* max. density	[g/cm ³]	1,85	1,5	1,3	1,25
Motor capacity 50 Hz	[kW]	0,060	0,060	0,060	-
Motor capacity 60 Hz	[kW]	0,072	0,072	0,072	0,072

Voltage	230 V AC or 230/400 V three phase current		
Current rating	0,7 A with AC or 0,5/0,29 A with three phase current		
Protection Class	Hose-proof according to IP 55		
Ports	Suction side G 1 1/4	Discharge side G 1	
Recommended max. Flow rate	Suction side 1 m/s	Discharge side 3 m/s	
Material	PP	PVDF	Edelstahl
max. Temperatur	80 °C	95 °C	95 °C
Max. system pressure (20°C)	1,0 bar	2,0 bar	10,0 bar
weight	2,7 kg	3,2 kg	3,2 kg

10.3 Performance charts

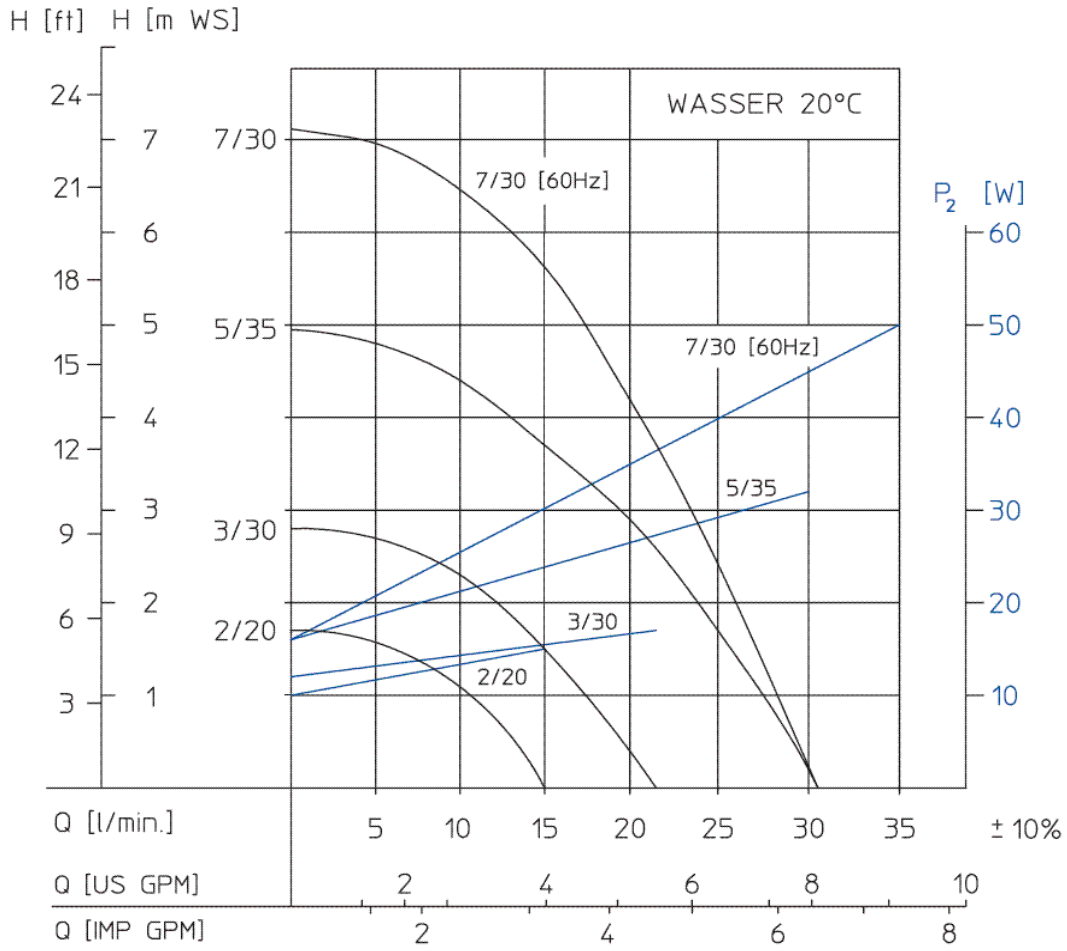

Measured with water at a temperature of 20°C.

10.4 Labour protection and accident prevention

NOTE

In order to protect their employees and other people as well as the environment from harmful influences and effects when handling hazardous substances, industrial and commercial companies are obliged to comply with legal provisions referring to labour protection such as the German Workplace Regulations (ArbStättV), Hazardous Substances Regulations (GefStoffV) and regulations for the prevention of accidents, as well as environmental regulations such as the German Waste Act (AbfG) and the Water Resources Law (WHG).

We therefore ask you to enclose a declaration of harmlessness with any pump or component you send us for repair. With this form duly filled in and signed, you declare that the pump or the component was cleaned and thoroughly rinsed with neutral fluid before being shipped to us. Notwithstanding this, we reserve the right to refuse acceptance of repair orders for any other reason.

So SONDERMANN products and their components are neither serviced nor repaired unless this declaration of harmlessness is enclosed (see page 25 below).

Pumps that have been operated with radioactive substances are not accepted at all.

In case that, although the pump was carefully emptied and cleaned, we have to take any safety precautions, you have to give us the necessary information when sending the pump or its component.

10.5 Declaration of harmlessness

The undersigned herewith declares that the following pump and its accessories are harmless and asks you to service and/or repair it or them.

Type of the pump:

.....
.....

Serial number:

.....

Date of delivery:

.....

Kind of problem:

.....
.....

We herewith declare that

the pump was not used to deliver harmful or noxious substances;

it was used with the following fluids:

.....
.....

before being shipped, the pump was carefully emptied and cleaned inside and out;

it is not necessary to take any special safety precautions;

you have to take the following safety precautions with regard to residual fluids and waste disposal:

.....
.....

Date:

signature:

S O N D E R M A N N

PUMPEN + FILTER GMBH & Co. KG

August-Horch-Str.4

D - 51149 Köln (Cologne - Germany)

Tel.: +49 (0) 2203/9394-0

Fax: +49 (0) 2203/9394-48

info@sondermann-pumpen.de

www.sondermann-pumpen.de

Subject to technical modification