

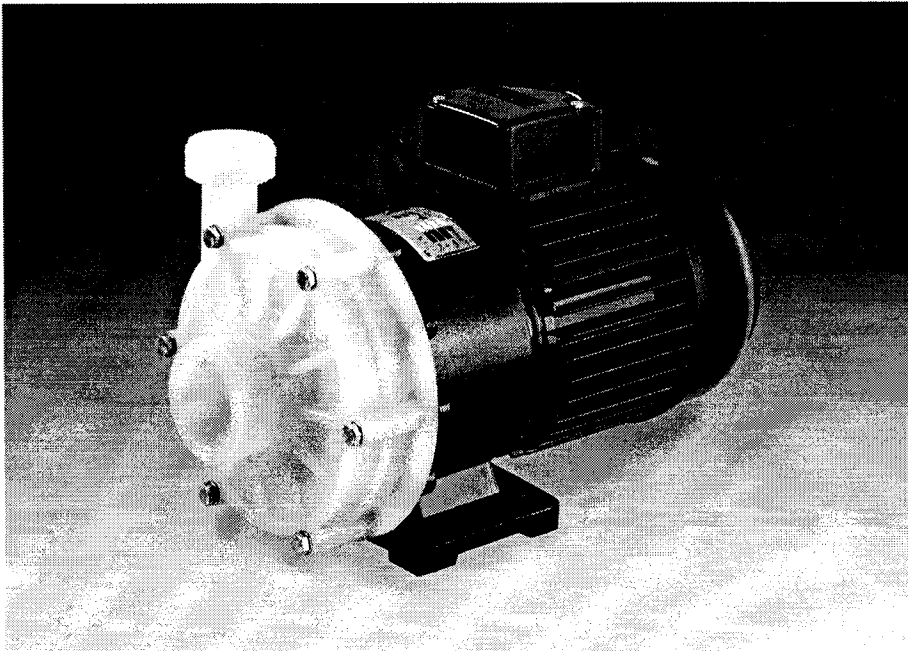

SONDERMANN
PUMPEN + FILTER GMBH & Co. KG

Operating Instructions

Magnetically coupled centrifugal pumps
Group 3 PP - PVDF



SONDERMANN
PUMPEN + FILTER GMBH & Co. KG

August-Horch-Straße 4 • D-51149 Köln
Tel. +49-2203-9394-0
Fax +49-2203-9394-48
info@sondermann-pumpen.de
www.sondermann-pumpen.de



SONDERMANN
PUMPEN + FILTER GMBH & Co. KG

EG-Konformitätserklärung

EC Declaration of Conformity

Déclaration de Conformité CE

Hiermit erklären wir, dass die Bauart der SONDERMANN magnetisch gekuppelte Kreiselpumpen 45 W - 7,5 kW in verschiedenen Werkstoffen und Ausführungen, in der gelieferten Ausführung folgenden einschlägigen Bestimmungen entspricht:

We herewith confirm that the construction of SONDERMANN magnetically coupled centrifugal pumps 45 W - 7,5 kW of different materials and versions corresponds to the following EC-rules:

Nous confirmons que la construction des pompes centrifuges à accouplement magnétique SONDERMANN, 45 W - 7,5 kW, de matériaux et versions différents est conforme aux dispositions réglementaires suivantes:

**(1) EG-Richtlinie Maschinen
98/37/EG**

**EC Machinery Directive
98/37/CE**

**Directive CE Machines
98/37/CE**

**(2) EG-Niederspannungsrichtlinie
73/23/EWG
93/68/EWG (1. Änderung)**

**EC Low Voltage Directive
73/23/EEC
93/68/EEC (1st Amendment)**

**Directive CE Bas Voltages
73/23/CEE
93/68/CEE (1ère Modification)**

Köln, 20.09.2005

SONDERMANN
PUMPEN + FILTER GMBH & Co. KG

Klaus Hahn
Geschäftsführer

OPERATING INSTRUCTIONS

TABLE OF CONTENTS

1	General information	1
1.1	Range of applications	1
1.2	Capacity ratings	1
2	Safety	2
2.1	Identification of safety instructions in the operating manual	2
2.2	Qualification and training of operating personnel	3
2.3	Hazards in the event of non-compliance with the safety instructions	3
2.4	Compliance with regulations pertaining to safety at work	3
2.5	Safety instructions relevant for operation	4
2.6	Safety instructions relevant for maintenance, inspection and assembly work	4
2.7	Unauthorized alterations and production of spare parts	4
2.8	Unauthorized modes of operation	5
3	Transportation and storage	5
3.1	Transportation	5
3.2	Storage	5
4	Product features and accessories	5
4.1	General description	5
4.2	Design	5
4.3	Accessories	6
5	Mounting and installation	6
5.1	Examples of mounting	7
5.2	Hoses and tubes	7
5.2.1	The suction line	8
5.2.2	The delivery line	8
5.3	Electrical connection	8
6	Starting and shutdown procedures	9
6.1	Preparations for starting	9
6.2	Starting procedure	9
6.3	Operation	10
6.4	Shutdown procedure	10
7	Maintenance	10
7.1	General information	10
7.2	Preventive maintenance	10
8	Troubleshooting	15
9	Parts illustration; spare parts list	16

1 General information

The pump may only be used in the range of applications authorised by the manufacturer. In case of modified operating conditions, please consult your supplier and/or the manufacturer.

1.1 Range of applications

- ☞ Delivery of low-viscosity liquids resembling water
- ☞ Delivery of acids, alkaline solutions etc.
- ☞ Delivery of gaseous fluids

WARNING

Make sure that the materials used for the pump are resistant to the fluids being delivered!

Note

Please ask the manufacturer for information on the chemical resistance of the materials used!

- ☞ If you deliver crystallising fluids, make sure that the fluid does not crystallise within the pump.

Should this happen, carefully clean all parts being in contact with the fluid once the pump has been shut off.

Note

Disassembly of the pump will cancel the right to all warranty claims!

1.2 Capacity ratings

Besides the operational data of the pump, the name plate also gives its type and serial number. Please cite these data when asking for additional information, placing reorders and, in particular, ordering spare parts. For additional information, please consult your supplier or the manufacturer.

Technical data:

Max. Flow:	look at name plate
Max. Head:	look at name plate
Materials:	look at name plate
Power supply:	look at name plate
Motor output:	look at name plate
Protection:	look at name plate
Weight	about 7 kg
The temperature of the fluids must not exceed the maximum value of:	
PP	80°C
PVDF	95°C
Maximum system pressure at 20°C	
PP	4 bar
PVDF	5 bar

Note

In order to determine the maximally allowed temperature of the fluid, please refer to the delivery note and/or the name plate for information on the materials used for the pump!

The letters on the name plate indicating the materials have the following meaning:

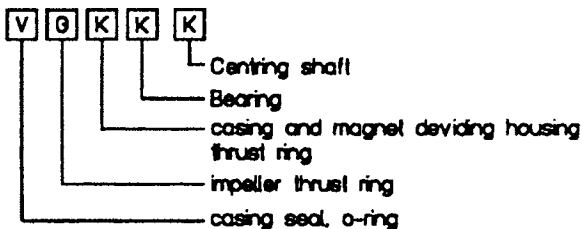

Packing

V = Viton
 E = EPDM
 P = Perbunan
 T = Viton coated with ETFE

K = Oxide ceramic
 G = Teflon-graphite

2 Safety

This operating manual gives basic instructions which are to be observed during installation, operation and

maintenance of the pump. It is therefore imperative that this manual be read by the responsible personnel / operator prior to assembly and commissioning. It is always to be kept available at the installation site.

It is not only the general safety instructions contained under this main heading safety that are to be observed but also the specific information provided under the other main headings.

2.1 Identification of safety instructions in the operating manual

Safety instructions given in this manual non-compliance with which would affect safety are identified by the following symbol:



see DIN 4844-W9

or where electrical safety is involved, with



see DIN 4844-W8

Instructions non-compliance with which would give rise to malfunctioning of the machinery are identified by the word

CAUTION

It is imperative that signs affixed to the machine, e.g.

- ☞ arrow indicating the direction of rotation
- ☞ symbols indicating fluid connections

be observed and kept legible.

2.2 Qualification and training of operating personnel

The personnel responsible for operation, maintenance, inspection and assembly must be adequately qualified. Scope of responsibility and supervision of the personnel must be exactly defined by the plant operator. If the staff does not have the necessary knowledge, they must be trained and instructed, which may be performed by the machine manufacturer or supplier on behalf of the plant operator. Moreover, the plant operator is to make sure that the contents of the operating manual are fully understood by the personnel.

2.3 Hazards in the event of non-compliance with the safety instructions

Non-compliance with the safety instructions may produce a risk to the personnel as well as to the environment and the machine and results in a loss of any right to claim damages.

For example, non-compliance may involve the following hazards:

- ☞ Failure of important functions of the machine / plant.
- ☞ Failure of specified procedures of maintenance and repair.
- ☞ Exposure of people to electrical, mechanical and chemical hazards.
- ☞ Endangering the environment owing to hazardous substances being released.

2.4 Compliance with regulations pertaining to safety at work

When operating the pump, the safety instructions contained in this manual, the relevant national accident prevention regulations and any other service and safety instructions issued by the plant operator are to be observed.

OPERATING INSTRUCTIONS

2.5 Safety instructions relevant for operation

- ☞ If hot or cold machine components involve hazards, they must be guarded against accidental contact.
- ☞ Guards for moving parts (e.g. coupling) must not be removed from the machine while in operation.
- ☞ Any leakage of hazardous (e.g. explosive, toxic, hot) fluids (e.g. from the shaft seal) must be drained away so as to prevent any risk occurring to persons or the environment. Statutory regulations are to be complied with.
- ☞ Hazards resulting from electricity are to be precluded (see, for example, the VDE Specifications and the bye-laws of the local power supply utilities).

2.6 Safety instructions relevant for maintenance, inspection and assembly work

It shall be the plant operator's responsibility to ensure that all maintenance, inspection and assembly work is performed by authorized and qualified personnel who have adequately familiarized themselves with

the subject matter by studying this manual in detail.

Any work on the machine shall only be performed when it is at a standstill, it being imperative that the procedure for shutting down the machine described in this manual be followed.

Pumps and pump units which convey hazardous media must be decontaminated.

On completion of work all safety and protective facilities must be re-installed and made operative again.

Prior to restarting the machine, the instructions listed under 'Initial commissioning' are to be observed.

2.7 Unauthorized alterations and production of spare parts

Any modifications may be made to the machine only after consultation with the manufacturer. Using spare parts and accessories authorised by the manufacturer is in the interest of safety. Use of other parts may exempt the manufacturer from any liability.

2.8 Unauthorized modes of operation

The reliability of the machine delivered will be only guaranteed if it is used in the manner intended, in accordance with clause 1 of this manual. The limit values specified in the data sheet must under no circumstances be exceeded.

3 Transportation and storage

3.1 Transportation

The pump is delivered by the manufacturer in a ready-to-work state. In the event of damages occurring during and due to transportation, the forwarding agent must make a factual statement. The pump should always be transported appropriately and according to the state of the art.

3.2 Storage

An eventual storage place must be absolutely dry. Make sure that the interior of the pump is protected from pollutants.

4 Product features and accessories

4.1 General description

This magnetically coupled centrifugal pump type 3 is a sucking single-stage centrifugal pump made of plastics and designed in modular system for horizontal mounting. The pump and electric motor are connected by a magnetic clutch which transmits the drive power to the impeller.

4.2 Design

The pump housing, impeller, impeller magnet, and magnet deviding housing are made of plastics or metal. In the standard version, the centre shaft is constructed from ceramic oxide whereas the bearings are made of ceramic oxide, PPS and/or teflon-graphite. The magnet deviding housing hermetically seals the fluid against all atmospheric influences. Due to the magnetic power transmission, the centre shaft needs not to be sealed. In contrast to mechanically or gland sealed pumps, this system prevents any leakage of fluid at the shaft.

OPERATING INSTRUCTIONS

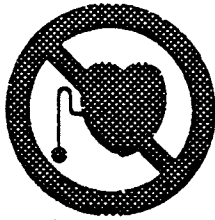

The pump is magnetically coupled. Attention: Coming in contact with permanent magnetic parts during repair or maintenance work dangerously exposes to magnetic forces which, for example, may influence pacemakers.

Keep your distance!

The pump housing parts are sealed by static O-rings. The impeller of the pump is a radial-flow wheel. Depending on the fluid to be delivered, each component of the pump is available in various materials.

Note

The materials used are listed on the name plate or the delivery note!

A choice of materials:

Pump housing,	PP, PVDF, PPS
Center shaft	oxide ceramics
Impeller and impeller magnet coating	PP, PVDF

Bearing	oxide ceramics, teflon-graphit
Static packings	Viton, EPDM. Viton coated with ETFE

4.3 Accessories

Hose nozzles, flanges and other components are available on request.

5 Mounting and installation

The pump should be installed at a place allowing easy access at all times. Normally, the ambient temperature should not exceed the following limits:



Note

In case of higher ambient temperatures please consult your supplier!

OPERATING INSTRUCTIONS

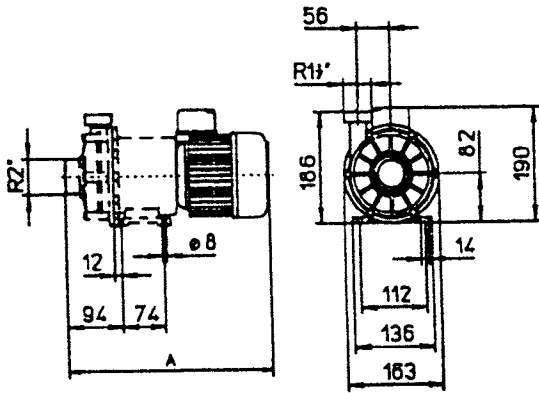

Subject to alteration.

Magnet length: 30mm

Power	Dimension "A"
0,37 u. 0,55kW	320mm

Magnet length: 60mm

Power	Dimension "A"
0,55kW	350mm
0,75kW	360mm

The suction side of the pump is provided with a male R2" thread and the delivery side with a male R1 1/2" thread.

5.1 Examples of mounting

The pump is set up to be mounted horizontally, but may also be mounted vertically, with the motor component pointing upwards. In this case, however, we recommend using an impeller starting ring made of ceramic (instead of the standard teflon-graphite version). Supply from a container located on the same level as the pump:

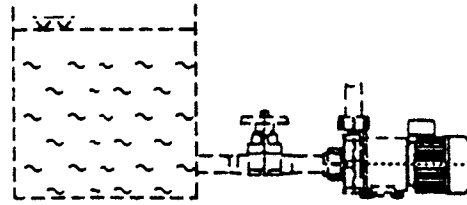

Supply from a container located higher than the pump:

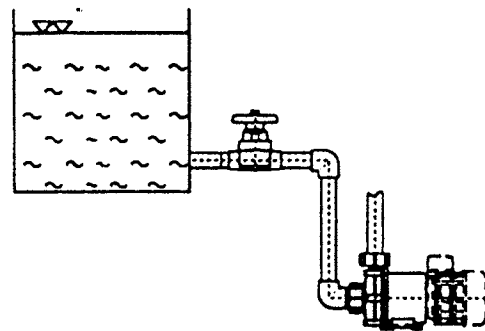

5.2 Hoses and tubes

The cross-sections of the tubes must correspond to the suction and delivery ports. All suction and delivery tubes to the pump housing should be free of tensile stress. The weight of the tubes must not rest on the housing!

WARNING

Do not install any quick-acting stop valves into the tubes! Pressure jerks may damage the pump housing!

OPERATING INSTRUCTIONS

5.2.1 The suction line

- ☞ The suction line must be a tube or hose which cannot be deformed by the resulting partial vacuum or by high temperatures.
- ☞ The suction line should be as short as possible and must be installed to prevent the accumulation of gas.
- ☞ When dimensioning the tubes, fittings etc., make sure that the flow resistances are kept as low as possible.
- ☞ The flow velocity within the piped suction line should not exceed the limit of 1m/s.

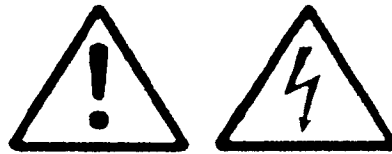
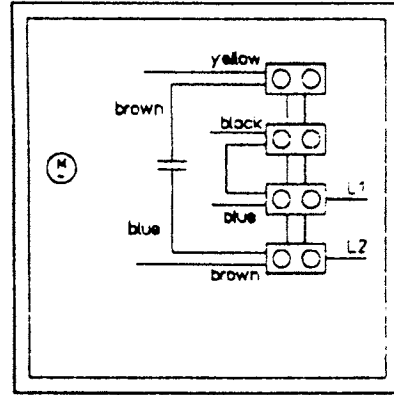

All electrical connections to the pump may only be performed by experts!

- ☞ The direction of rotation indicated by an arrow on the pump must be respected and controlled after installation.

WARNING

Do not check the direction of rotation without having filled fluid in the pump!

5.3 Electrical connection

AC motors should be connected according to the following illustration:

- ☞ The motor must be equipped with a motor protection switch and a temperature sensor.

Note

Motor protection devices can be delivered by the manufacturer!

- ☞ The power supply must have been cut for at least 5 minutes before you may start any work at the terminal box of the pump.
- ☞ Make sure that the data given on the name plate correspond to the existing power supply.
- ☞ All electrical connections and installations of additional protection devices should be performed by an expert in accordance with the instructions of the local power suppliers and/or the Association of German Electrotechnical Engineers VDE.

6 Starting and shutdown procedures

6.1 Preparations for starting

- ☞ The pump housing and the suction line must be filled with water or the fluid to be delivered.

WARNING

Avoid any dry-running of the pump!

Note

We recommend installing dry-running protection devices such as flow indicators, contact manometers, differential pressure switches or level controllers. All these devices can be supplied with the pump!

- ☞ Tighten all screwed connections and fittings.
- ☞ Entirely open all shut-off devices of the suction and delivery lines.

6.2 Starting procedure

- ☞ Switch on the motor.
- ☞ Adjust the operating point by slowly closing the shut-off device of the delivery line. If there is no shut-off device installed, the operating point will be adjusted automatically in accordance with the pump curve.

WARNING

Do not run the pump with a closed delivery line for a longer period of time. This may heat up the fluid inside the pump housing and thus damage interior components of the pump!

WARNING

Always protect the pump from coarse impurities and magnetisable metal particles!

6.3 Operation

If the motor has been switched off by the motor protection switch, proceed as follows:

- ☞ Before switching on the motor again, check whether the impeller rotates readily.
- ☞ Make sure that the suction line and the pump housing are filled with fluid.
- ☞ Switch on the motor.

If the pump only delivers for a short period of time and then stops delivering, the magnetic clutch has been

disengaged. Proceed as described in chapter 8 below.

6.4 Shutdown procedure

- ☞ Switch off the motor.
- ☞ Close all shut-off devices.
- ☞ In case some fluid remains within the pump, secure the shut-off devices to prevent an accidental opening.

7 Maintenance

7.1 General information

The pump is designed for continuous operation and is therefore maintenance-free.

7.2 Preventive maintenance

- ☞ Clean the ventilator cowl at least once per month in order to prevent the motor from overheating.
- ☞ Although bearings, centre shaft and starting rings are also designed for continuous operation, they should periodically be inspected for choking. If dirty, silty or crystallising fluids are delivered, then the pump should be inspected

OPERATING INSTRUCTIONS

and, if necessary, cleaned at shorter intervals.

Note

The sleeve bearings consist of:

- 1 bearing for magnetic clutches 30mm long*
- 2 bearings and 1 spacer for magnetic clutches 60mm long*

WARNING

Make sure there are no magnetisable metal particles in the working area if you assemble or disassemble the pumps!



When the pump outlet/impeller casing is assembled or disassembled, magnetic forces can cause serious injury!

OPERATING INSTRUCTIONS

Disassembly of the pump:

1. Remove the 6 screws (901.1) in the pump housing (101)

Required tool: fork or ring spanner, size 13

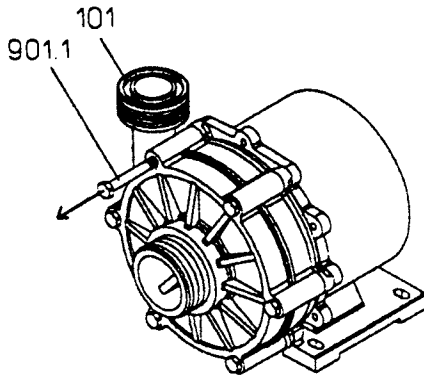

2. Take the complete head of the pump (001) off the lantern (113).

Required tool: tire lever

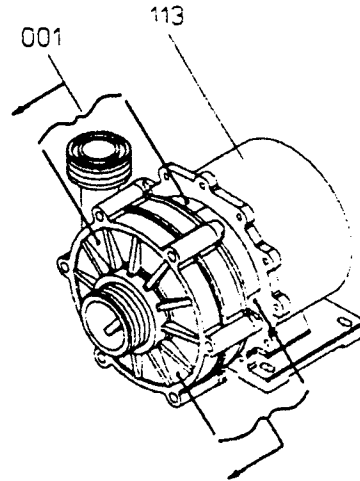

3. Take the pump housing (101) off the center shaft (211) and pull the impeller magnet (847.1) together with the impeller (230) out of the magnet deviding housing (161).

No tools required!!

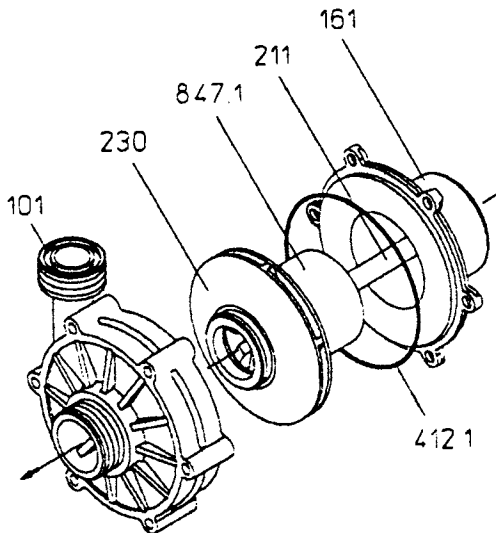

4. Remove the bearings (310.1 and 310.2) by forcing them backwards out of the impeller magnet (847.1).

Required tools: hand lever press + pin $\varnothing 20\text{mm}$

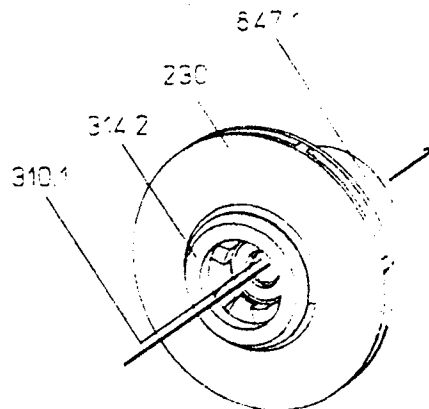

OPERATING INSTRUCTIONS

5. Remove the impeller (230) from the impeller magnet (847.1).

Required tool: tire lever

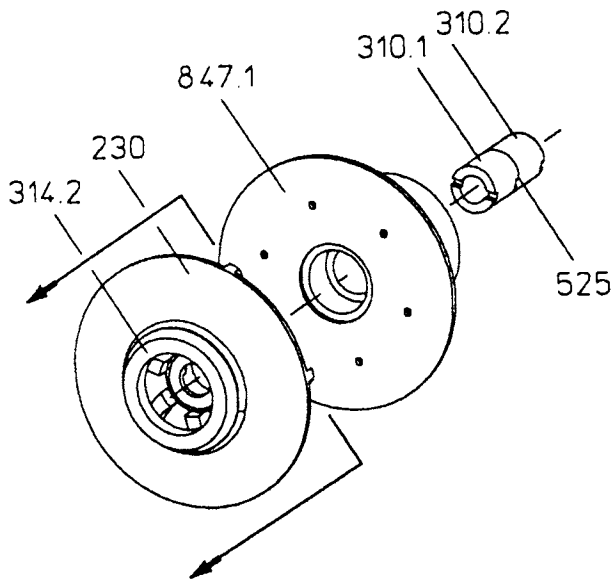

6. Take the thrust ring (314.2) off the impeller (230).

Required tools: tubular piece \varnothing inside 80mm; drift pin \varnothing 6mm

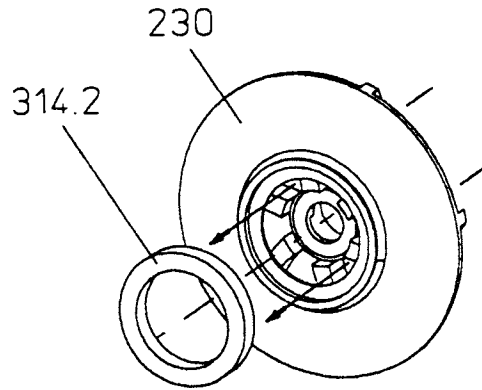

Re-assembly of the pump:

7. Assemble the bearings (310.1 and 310.2)

Required tool: hand lever press

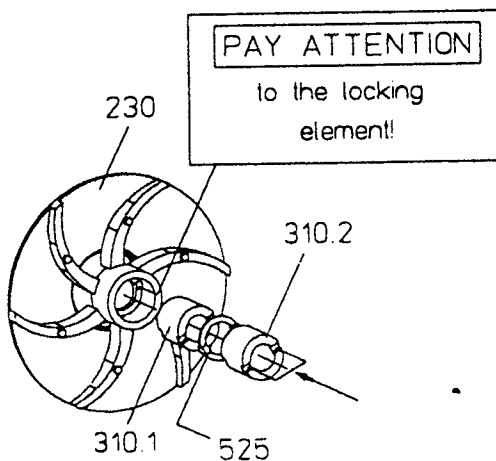

8. Press the impeller (230) onto the impeller magnet (847.1).

Required tools: hand lever press + plastic pressure disk \varnothing 80mm

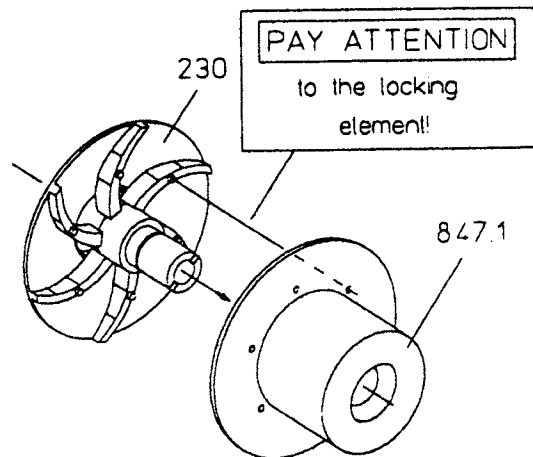

WARNING

After having replaced the bearings and before re-assembling the pump outlet/impeller casing, check manually if the impeller magnet (847.1) and bearings (310) readily rotate on the centre shaft (211)!

and jam the impeller, once the pump is started again.

To assemble the pump outlet/impeller casing, repeat step 1 to 3 in reverse order.

WARNING

Once the pump outlet/impeller casing has been assembled, the impeller (230) and impeller magnet (847.1) should be able to slide axially on the centre shaft!

- ☞ Any other repair than the replacement of worn parts should be done by an expert, since inappropriate maintenance work usually results in unnecessary costs.
- ☞ If the pump will not be in operation for a longer period of time, it should be cleaned carefully. Otherwise you risk that residues remaining in the pump may harden

OPERATING INSTRUCTIONS

8 Troubleshooting

Malfunction	Causes	Corrective action
Pump does not work when switched on	No voltage	Test the voltage
	Impurities in the pump housing	Remove the impurities
Magnetic clutch is disengaged	Specific gravity and/or viscosity of the fluid is too high	Reduce the delivery rate; use a stronger magnetic clutch and a more powerful motor
	Pump was switched off, then switched on again before the rotor stopped	The rotor should have stopped before the pump can be switched on again
Motor is overheating	Clogged ventilator cowl	Clean the ventilator and the cowl
Pump is working, but not delivering	Gas accumulation in the lines	Evacuate the lines
Too much flow noise	Cavitation	Increase the suction line cross-section
		Reduce the delivery rate
		cool down the fluid
Pump is not sucking	No fluid in the pump	Open the vane
Delivery rate too low	Air in the system	Evacuate the system
	Suction and delivery line cross-sections are too small (significant losses)	Increase the suction and delivery line cross-sections
	Valve is not entirely open	Entirely open the valve
Delivery rate too high	Pump losses are less significant than presumed	Install a flow control valve in the delivery line